

# Manual of Power Factor Correction

Information Tables Formulas

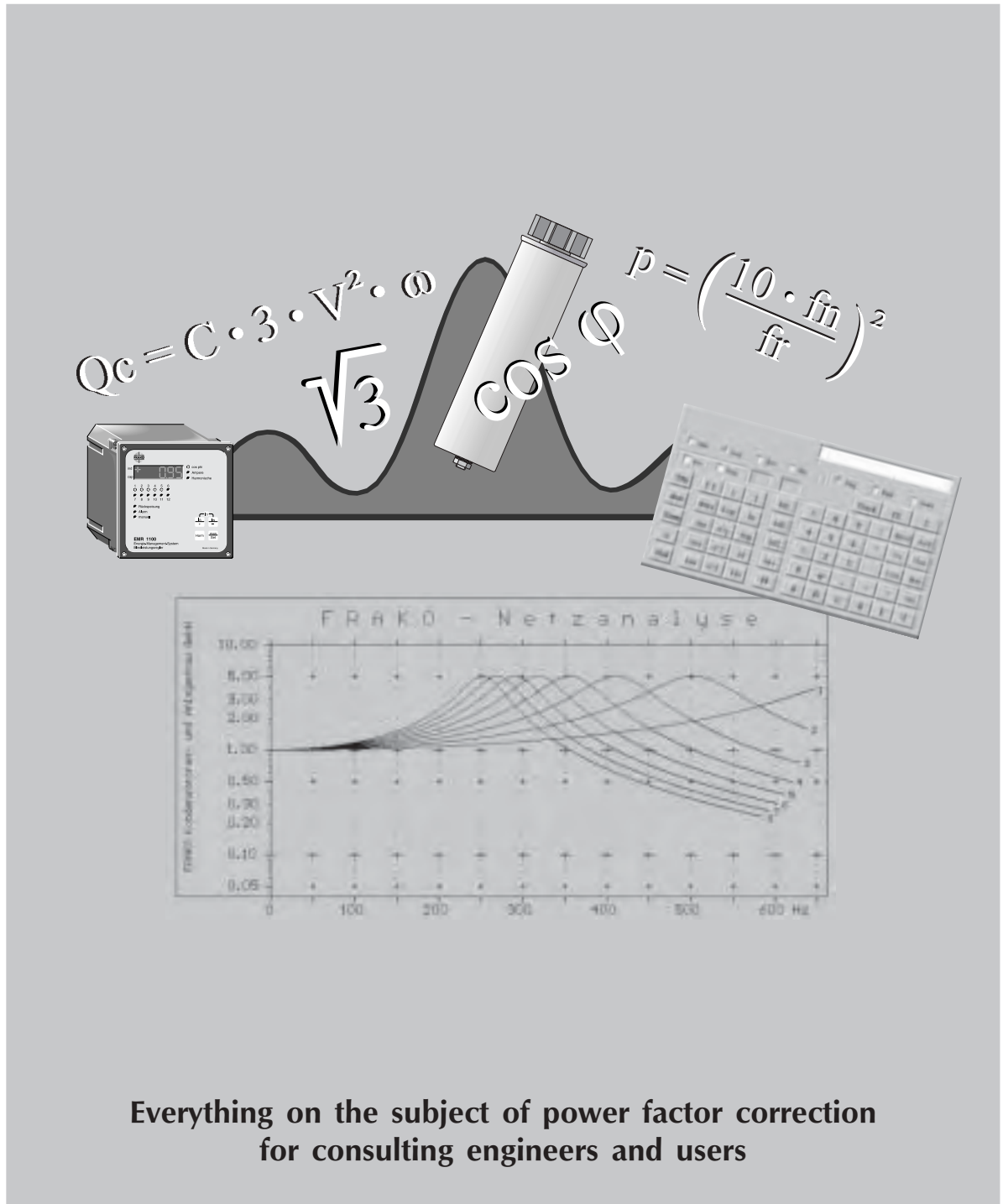

Everything on the subject of power factor correction  
for consulting engineers and users

Power factor correction (PFC) is one of the best investments to reduce energy costs with a short payback. Developments in recent years have improved the reliability and capacity of compensation equipment and simplified its commissioning.

In a large number of cases, the design and dimensioning work has been made more difficult by the fact that, in a company's internal low-voltage installation, and also in the medium-voltage supplying it, the proportion of network harmonics has grown from year to year. Power converters, electronically controlled drives, static frequency converters, televisions and computers feed harmonic currents into the supply network. These harmonics might be amplified by the network impedances and capacitors installed.

Effective measures must be taken right at the design stage in order to prevent this phenomenon becoming a problem later on.

It is over 18 years since FRAKO specialists established the fundamental principles for analysing supply networks, and their work has repeatedly been the subject of publications since then. It therefore seemed to us to be a logical step to summarise this information in a manual.

PFC systems are installed to cut costs. The investment in such a system typically has a payback period of 1 1/2 to 3 years, following which the user will „profit“ from the system. It is therefore important to be absolutely certain that the compensation system would have as long a service life as possible when contemplating its procurement.

One of the greatest challenges confronting FRAKO's development department was to develop power capacitors and factory-assembled systems that are both less expensive and have a long life expectancy. We use the expressions

- „field-proven life expectancy“ and
- „high load-rating quality characteristic“

to describe the result of these innovations.

Field-proven life expectancy involves rigorous monitoring and documentation of all failures occurring in the field. FRAKO has been doing this since 1991 and can demonstrate that, over this period of time, the failure rate for FRAKO power capacitors has only amounted to 200 ppm (parts per million).

High load-rating quality characteristic means that FRAKO power capacitors:

- can continuously sustain a current that is double the rated current at 400 V,
- can tolerate transient current peaks of up to 300 times the rated current at 400 V,
- have a capacitor voltage rating of 440 V (7% filter circuit) to 525 V (with 14 % filter circuit) for a 400 V power distribution system,
- have an allowable case temperature of 75 °C.

FRAKO Application Know-how and FRAKO product quality are the prerequisites to provide the maximum benefit to the user. FRAKO hopes that this manual will become an indispensable aid to the specialist.

Teningen, March, 2002

FRAKO Kondensatoren- und Anlagenbau GmbH

A handwritten signature in dark ink, appearing to read "H.G. Mall".

H.G. Mall

	Page
<b>Basic theory</b>	<b>4</b>
• Active power/Active and reactive power	4
• Reactive power/Apparent power/Power factor ( $\cos \varphi$ )	5
• Why correct power factor?	6
<b>Correction methods</b>	<b>7</b>
• Individual power factor correction	7
• Group power factor correction	7
• Central power factor correction	8
• Hybrid power factor correction	8
<b>Determination of required capacitor rating</b>	<b>9</b>
• Tariffs/Approximate estimates	9
• Determination of required capacitor rating by measurement	10
• Measurement by reading meters	11
• Determination of required capacitor rating from the utility company's invoice	13
<b>Applications</b>	<b>14</b>
• Single power factor correction for transformers	16
• Single power factor correction for motors	17
• Power factor correction systems	20
<b>Features</b>	<b>21</b>
• Power capacitors	21
• Reactive power control relays	23
<b>Installation</b>	<b>26</b>
• Current transformers	26
• Fuses and cables	27
• Protection	29
<b>Capacitor calculation formulas</b>	<b>30</b>
<b>Harmonics</b>	<b>31</b>
• What are harmonics/How are harmonics produced ?	31
• What is the level of these harmonics if no p.f. correction system has yet been installed?	32
• What effect does a power factor correction system have on a network with harmonics?	33
• When can dangerous network resonances occur?	34
• What effect does the network configuration have on the problem of harmonics?	34
• Voltage and current loads of unchoked power factor correction systems	34
<b>Project engineering for networks with harmonics</b>	<b>35</b>
• Measures to counteract expected resonances	36
<b>Project engineering in networks with audiofrequency remote control systems</b>	<b>37</b>
• Effect of unchoked power factor correction systems	38
• Critical remote control frequencies in the range 270 to 425 Hz	38
• Effect of choked power factor correction systems	39
• Types of choked power factor correction systems	39
• Monitoring power factor correction systems in industrial facilities	41
<b>Active filters</b>	<b>42</b>
• Operating principle	42
• Applications	43

Before venturing into the details in the design of power factor correction systems, we would first like to present a brief refresher of basic alternating current circuit theory.

## Active power

With a purely resistive load with no inductive or capacitive components, such as in an electric heater, the voltage and current curves intersect the zero co-ordinate at the same point (Fig. 1). The voltage and current are said to be "in phase". The power (P) curve is calculated from the product of the momentary values of voltage (V) and current (I). It has a frequency which is double that of the voltage supply, and is entirely in the positive area of the graph, since the product of two negative numbers is positive, as, of course, is the product of two positive numbers.

In this case:  $(-V) \cdot (-I) = (+P)$ .

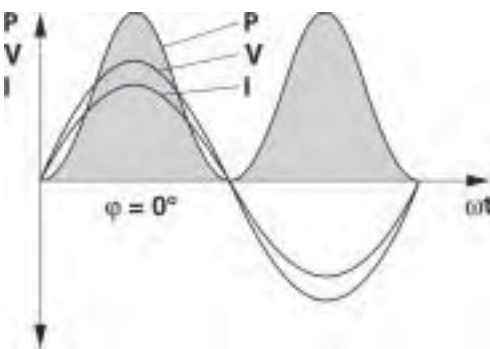

Active or real power is that component of the power that is converted into another form (e.g. heat, light, mechanical power) and is registered by the meter.

With a purely resistive or ohmic load it is calculated by multiplying the effective value of voltage [U] by the current [I]:

$$P = V \cdot I$$

[W] [V] [A]

**Fig. 1:** Voltage, current and power curve for a purely resistive load ( $\varphi = 0^\circ$ )

## Active and reactive power

In practice, however, it is unusual to find purely resistive loads, since an inductive component is also present. This applies to all consumers that make use of a magnetic field in order to function, e.g. induction motors, chokes and transformers. Power converters also require reactive current for commutation purposes. The current used to create and reverse the magnetic field is not dissipated but flows back and forth as reactive current between the generator and the consumer.

As Fig. 2 shows, the voltage and current curves no longer intersect the zero co-ordinate at the same points. A phase displacement has occurred. With inductive loads the current lags behind the voltage, while with capacitive loads the current leads the voltage. If the momentary values of power are now calculated with the formula  $(P) = (V) \cdot (I)$ , a negative product is obtained whenever one of the two factors is negative.

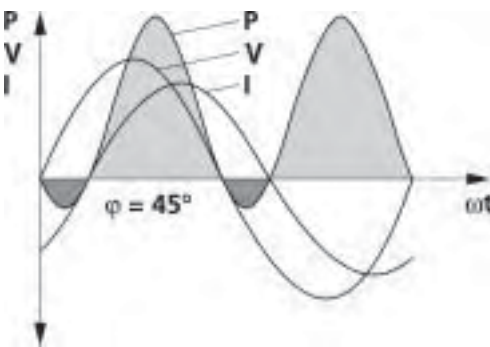

In this example phase displacement  $\varphi = 45^\circ$  has been chosen. This corresponds to an inductive  $\cos \varphi$  of 0.707. Part of the power curve can be seen to be in the negative area.

The active power in this case is given by the formula:

$$P = V \cdot I \cdot \cos \varphi$$

[W] [V] [A]

**Fig. 2:** Voltage, current and power with a resistive and inductive load ( $\varphi = 45^\circ$ )

## Reactive power

Inductive reactive power occurs in motors and transformers when running under no-load conditions if the copper, iron and, where appropriate, frictional losses are ignored. With FRAKO power capacitors we can think in terms of virtually pure capacitive reactive power, since these display extremely low losses (less than 0,05 %).

If the voltage and current curves are 90° out of phase, one half of the power curve lies in the positive area, with the other half in the negative area (Fig. 3). The active power is therefore zero, since the positive and negative areas cancel each other out.

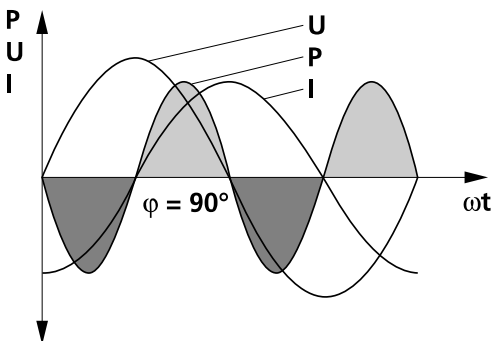

**Fig. 3:** Voltage, current and power curves under a purely reactive load ( $\varphi = 90^\circ$ )

**Reactive power is that power which flows between the generator and the consumer at the same frequency as the supply voltage in order for the magnetic/electric field to build up and decay.**

$$Q = U \cdot I \cdot \sin \varphi$$

[VAr] [V] [A]

## Apparent power

The apparent power is critical for the rating of electric power networks. Generators, transformers, switchgear, fuses, circuit breakers and conductor cross-sections must be adequately dimensioned for the apparent power that results in the system.

The apparent power is the product obtained by multiplying the voltage by the current without taking into account the phase displacement.

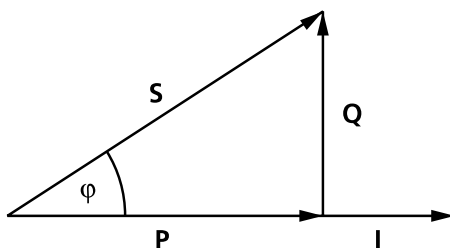

**Fig. 4:** Power triangle

$$S = V \cdot I$$

[VA] [V] [A]

The apparent power is given by the vector addition of active power and reactive power:

$$S = \sqrt{P^2 + Q^2}$$

[VA] [W] [VAr]

## Power factor (cos φ)

The cosine of the angle of phase displacement between current and voltage is a convenient parameter for calculating the active and reactive components of power, voltage and current. In electrical engineering practice, this parameter has come to be termed the power factor.

$$\cos \varphi = \frac{P}{S} \text{ [W]/[VA]}$$

The power factor at full load is normally given on the nameplates of the electrical machines.

As the power distribution system must be dimensioned to carry the apparent power, efforts are made to keep this as low as possible. If appropriately dimensioned capacitors are installed in parallel with the consumers, the reactive current circulates back and forth between the capacitor and the consumer. This means that the rest of the distribution network is not subject to this additional current. If a power factor of 1 is achieved by this collective measurement, the only current flowing in the distribution system is active current.

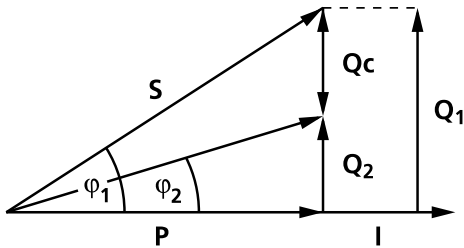

The reactive power  $Q_c$  corrected by the capacitor is given by the difference between the inductive reactive power  $Q_1$  before correction and the reactive power  $Q_2$  after correction, i.e.  $Q_c = Q_1 - Q_2$ .

$$Q_c = P \cdot (\tan \varphi_1 \cdot \tan \varphi_2)$$

[VAr] [W]

**Fig. 5:** Power triangle showing the effect of correction

### Why correct power factor?

The reactive current circulating between the utility company's generator and the consumer converts electrical energy into heat in the power distribution system, and there is an additional load on generators, transformers, cables and switchgear. Energy losses and voltage drops are incurred. If there is a high proportion of reactive current, the installed conductor cross sections cannot be fully utilised for transmitting useful power, or must be appropriately oversized. From the utility company's standpoint, a poor power factor increases the investment and maintenance costs for the power distribution system, and these additional costs are passed on to those responsible, i.e. those power consumers with poor power factors. A meter for reactive energy is therefore installed in addition to the one for active energy.

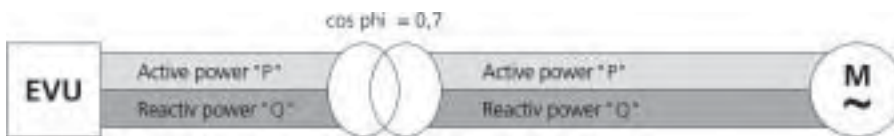

**Fig. 6:** Active and reactive power in the power distribution system: without compensation

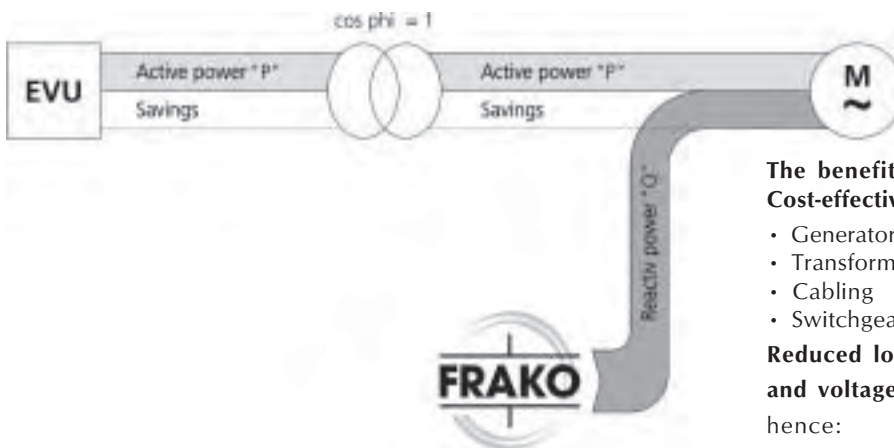

**The benefits:**

**Cost-effective utilisation of:**

- Generators (utility company)
- Transformers
- Cabling
- Switchgear

**Reduced losses and voltage drops**

hence:

**lower energy costs!**

**Fig. 7:** Active and reactive power in the power distribution system: with correction

## Individual power factor correction

In the most simple case, an appropriately sized capacitor is installed in parallel with each individual inductive consumer. This completely eliminates the additional load on the cabling, including the cable feeding the compensated consumer. The disadvantage of this method, however, is that the capacitor is only utilised during the time that its associated consumer is in operation. Additionally, it is not always easy to install the capacitors directly adjacent to the machines that they compensate (space constraints, installation costs).

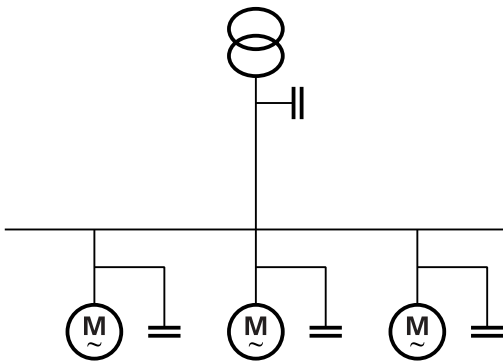

*Fig. 8: Typical individual power correction*

## Group power factor correction

Electrical machines that are always switched on at the same time can be combined as a group and have a joint correction capacitor. An appropriately sized unit is therefore installed instead of several smaller individual capacitors.

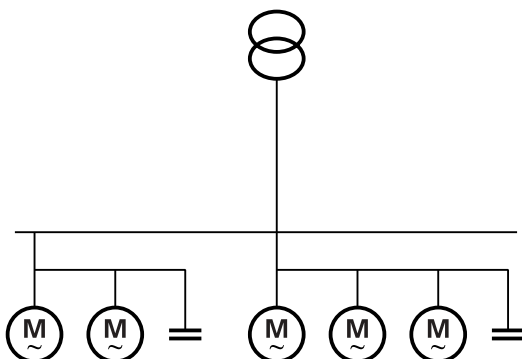

*Fig. 9: Typical group power factor correction*

### **Applications:**

- To compensate the no-load reactive power of transformers
- For drives in continuous operation
- For drives with long power supply cables or cables whose cross section allows no margin for error

### **Advantages:**

- Reactive power is completely eliminated from the internal power distribution system
- Low costs per kVAr

### **Disadvantages:**

- The power factor correction system is distributed throughout the entire facility
- High installation costs
- A larger overall capacitor power rating is required as the coincidence factor cannot be taken into account

### **Applications:**

- For several inductive consumers provided that these are always operated together

### **Advantages:**

- Similar to those for individual power factor correction, but more cost-effective

### **Disadvantages:**

- Only for groups of consumers that are always operated at the same time

## Central power factor correction

The power factor correction capacitance is installed at a central point, for example, at the main low voltage distribution board. This system covers the total reactive power demand. The capacitance is divided into several sections which are automatically switched in and out of service by automatic reactive power control relays and contactors to suit load conditions.

This method is used today in most instances. A centrally located power factor correction system is easy to monitor. Modern reactive power control relays enable the contactor status,  $\cos \phi$ , active and reactive currents and the harmonics present in the power distribution system to be monitored continuously. Usually the overall capacitance installed is less, since the coincidence factor for the entire industrial operation can be taken into account when designing the system. This installed capacitance is also better utilised. It does not, however, eliminate the reactive current circulating within the user's internal power distribution system, but if adequate conductor cross sections are installed, this is no disadvantage.

### Applications:

- Can always be used where the user's internal power distribution system is not underdimensioned

### Advantages:

- Clear-cut, easy-to-monitor concept
- Good utilisation of installed capacitance
- Installation usually relatively simple
- Less total installed capacitance, since the coincidence factor can be taken into account
- Less expensive for power distribution systems troubled by harmonics, as controlled devices are simpler to choke

### Disadvantages:

- Reactive currents within the user's internal power distribution system are not reduced
- Additional costs for the automatic control system

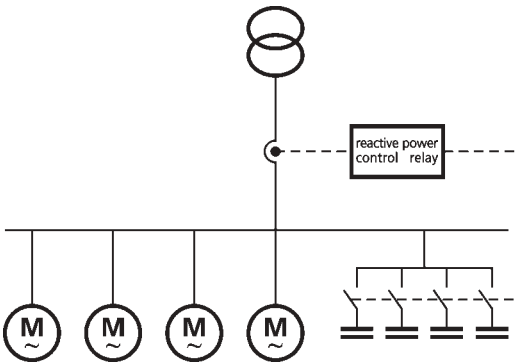

**Fig. 10:** Typical central power factor correction system

## Hybrid power factor correction

Economic considerations often show that it is advantageous to combine the three methods described above.

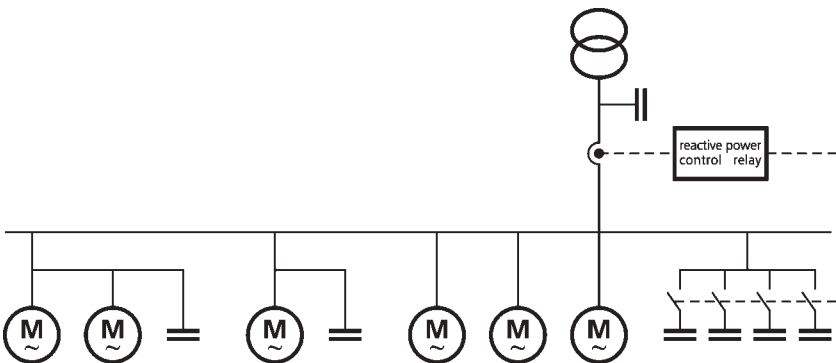

**Fig. 11:** Typical hybrid power factor correction system





# Determination of required capacitor rating

## Tariffs

Utility companies as a rule have fixed tariffs for their smaller power consumers, while individual supply contracts are negotiated with the larger consumers.

With most power supply contracts the costs for electrical power comprise:

- Power [kW], – measured with a maximum demand meter, e.g. monthly maximum demand over a 15 minute period.
- Active energy [kWh], – measured with a watt-hour meter usually split into regular and off-peak tariffs.
- Reactive energy [kVArh], – measured with a reactive current meter, sometimes split into regular and off-peak tariffs.

It is normal practice to invoice the costs of reactive energy only when this exceeds 50% of the active power load. This corresponds to a power factor  $\cos \varphi = 0.9$ . It is not stipulated that the power factor must never dip below this value of 0.9. Invoicing is based on the power factor monthly average. Utility companies in some areas stipulate other power factors, e.g. 0.85 or 0.95.

With other tariffs the power is not invoiced as kW but as kVA. In this case the costs for reactive energy are therefore included in the power price. To minimise operating costs in this case, a power factor  $\cos \varphi = 1$  must be aimed for. In general, it can be assumed that if a power factor correction system is correctly dimensioned, the entire costs for reactive energy can be saved.

## Approximate estimates

Accurate methods for determining the required reactive capacity are given in a subsequent section of this manual. Sometimes, however, it is desirable to estimate the approximate order of magnitude quickly. Cases may also occur where an engineer has performed an accurate calculation but is then uncertain of the result, in case somewhere a mistake has occurred in his or her reasoning. This can then be used to verify that the results calculated have the right magnitude.

With this "rule of thumb", the order of magnitude derived is at least a right approximation, provided that the constellation of the consumers installed in the facility does not deviate too radically from normal industrial practice.

**Table 1: Approximate estimates for the required reactive capacitor rating**

Consumer	Capacitor rating
• Motors with individual PFC	• 35 – 40% of motor rating
• Transformers with individual PFC	• 2.5% of transformer capacity • 5% for older transformers
• Central PFC	• 25 – 33% of transformer capacity when aiming for $\cos \varphi = 0.9$ • 40 – 50% of transformer capacity when aiming for $\cos \varphi = 1$

## Consumer list

When designing a new installation for a new plant or a section of a plant, it is appropriate to first make an approximate estimate of requirements. A more accurate picture is achieved by listing the consumers to be installed, together with their electrical data, by taking into account the coincidence factor. In cases where a later extension may be considered, the power factor correction system should be designed and installed so that the extension will not involve great expenditure. The cabling and protected circuits to the power factor correction system should be dimensioned to cater for expansion, and space should be reserved for additional capacitor units.

## Determination of required capacitor rating by measurement

### Measurement of current and power factor

Ammeters and power factor meters are often installed in the main low-voltage distribution board, but clamp meters are equally effective for measuring current. Measurements are made in the main supply line (e.g. transformer) or in the line feeding the equipment whose power factor is to be corrected. Measuring the voltage in the power distribution system at the same time improves the accuracy of the calculation, or the nominal voltage (e.g. 380 or 400 V) may simply be used instead.

The active power  $P$  is calculated from the measured voltage  $V$ , apparent current  $I_S$  and power factor:

$$P = \sqrt{3} \cdot U \cdot I_S \cdot \cos \varphi \cdot 10^{-3}$$

[kW]      [V] [A]

If the desired power factor  $\cos \varphi$  has been specified, the capacitor power rating can be calculated from the following formula. It is, however, simpler to read off the factor  $f$  from the Table 2 and multiply it by the calculated active power.

$$Q_C = P \cdot (\tan \varphi_1 \cdot \tan \varphi_2)$$

[VAr] [W]

or:

$$Q_C = P \cdot f$$

[var] [W]

**Example:** Measured apparent current  $I_S$ : 248 A  
 Power factor  $\cos \varphi_1$ : 0.86  
 Desired  $\cos \varphi_2$ : 0.92  
 Voltage  $V$ : 397 V

Calculation:

$$P = \sqrt{3} \cdot 397 \cdot 248 \cdot 0.86 \cdot 10^{-3}$$

$$P = 146.6 \text{ kW}$$

From Table 2 we obtain:

$$\text{Factor } f = 0.17$$

Required capacitor rating:

$$Q_C = 146.6 \cdot 0.17 = \underline{24.9 \text{ kVAr}}$$

### Note:

Measurements made as described above naturally only give momentary values. The load conditions can, however, vary considerably depending on the time of day and the season of the year. Measurements should therefore be made by someone who is familiar with the installation. Several measurements should be made, ensuring that the consumers whose power factor is to be corrected are actually switched on. The measurements should also be made quickly - if possible reading all instruments simultaneously - so that any sudden change of load does not distort the results.

## Measurements with recording of active and reactive power

More reliable results are obtained with recording instruments. The parameters can be recorded over a longer period of time, peak values also being included. Required capacitor power rating is then calculated as follows:

$Q_C$  = required capacitor rating

$Q_L$  = measured reactive power

$P$  = measured active power

$\tan \varphi_2$  = the corresponding value of  $\tan \varphi$  at the desired  $\cos \varphi$  (can be obtained from Table 2, e.g. when  $\cos \varphi = 0.92$  the corresponding  $\tan \varphi = 0.43$ )

$$Q_C = Q_L - (P \cdot \tan \varphi_2)$$

[VAr] [VAr] [W]

## Measurement by reading meters

The active and reactive current meters are read at the start of a shift. Eight hours later both meters are read again. If there has been a break in operation during this time, the eight hours must be extended by the duration of this break.

$RM_1$  = reactive current meter reading at start

$RM_2$  = reactive current meter reading at finish

$AM_1$  = active current meter reading at start

$AM_2$  = active current meter reading at finish

$$\frac{RM_2 - RM_1}{AM_2 - AM_1} = \tan \varphi$$

Using this calculated value of  $\tan \varphi$  and the desired  $\cos \varphi$  we can then obtain the factor  $f$  from Table 2. The parameter  $k$  is the ratio of the meter current transformers. The required capacitor power rating can thus be derived:

$$Q_C = \frac{(AM_2 - AM_1) \cdot k}{8} \cdot f$$

**Example:** The following meter readings have been noted:

active current meter ( $AM_1$ )...115.3 kWh

( $AM_2$ )...124.6

reactive current meter ( $RM_1$ )...311.2 kVAr

( $RM_2$ )...321,2

The meters work with 150/5 A current transformers, so here the factor is  $k = 30$ .

Calculation:

$$\tan \varphi = \frac{321.2 - 311.2}{124.6 - 115.3} = 1.08$$

For a desired  $\cos \varphi$  of 0.92 a factor  $f$  of 0.65 is obtained from Table 2.

The capacitor power rating is thus

$$Q_C = \frac{(124.6 - 115.3) \cdot 30}{8} \cdot 0.65 = \underline{\underline{22.67 \text{ kVAr}}}$$



## Determination of required capacitor rating

Table 2: Factor  $f$  ( $f = \tan \varphi_{\text{actual}} - \tan \varphi_{\text{desired}}$ )

Uncorrected		Desired $\cos \varphi$						
$\tan \varphi$	$\cos \varphi$	<b>0,80</b>	<b>0,85</b>	<b>0,90</b>	<b>0,92</b>	<b>0,95</b>	<b>0,98</b>	<b>1,00</b>
3.18	<b>0.30</b>	2.43	2.56	2.70	2.75	2.85	2.98	3.18
2.96	<b>0.32</b>	2.21	2.34	2.48	2.53	2.63	2.76	2.96
2.77	<b>0.34</b>	2.02	2.15	2.28	2.34	2.44	2.56	2.77
2.59	<b>0.36</b>	1.84	1.97	2.10	2.17	2.26	2.39	2.59
2.43	<b>0.38</b>	1.68	1.81	1.95	2.01	2.11	2.23	2.43
2.29	<b>0.40</b>	1.54	1.67	1.81	1.87	1.96	2.09	2.29
2.16	<b>0.42</b>	1.41	1.54	1.68	1.73	1.83	1.96	2.16
2.04	<b>0.44</b>	1.29	1.42	1.56	1.61	1.71	1.84	2.04
1.93	<b>0.46</b>	1.18	1.31	1.45	1.50	1.60	1.73	1.93
1.83	<b>0.48</b>	1.08	1.21	1.34	1.40	1.50	1.62	1.83
1.73	<b>0.50</b>	0.98	1.11	1.25	1.31	1.40	1.53	1.73
1.64	<b>0.52</b>	0.89	1.02	1.16	1.22	1.31	1.44	1.64
1.56	<b>0.54</b>	0.81	0.94	1.07	1.13	1.23	1.36	1.56
1.48	<b>0.56</b>	0.73	0.86	1.00	1.05	1.15	1.28	1.48
1.40	<b>0.58</b>	0.65	0.78	0.92	0.98	1.08	1.20	1.40
1.33	<b>0.60</b>	0.58	0.71	0.85	0.91	1.00	1.13	1.33
1.30	<b>0.61</b>	0.55	0.68	0.81	0.87	0.97	1.10	1.30
1.27	<b>0.62</b>	0.52	0.65	0.78	0.84	0.94	1.06	<b>1.27</b>
1.23	<b>0.63</b>	0.48	0.61	0.75	0.81	0.90	1.03	1.23
1.20	<b>0.64</b>	0.45	0.58	0.72	0.77	0.87	1.00	1.20
1.11	<b>0.67</b>	0.36	0.49	0.63	<b>0.68</b>	0.78	0.90	1.11
1.08	<b>0.68</b>	0.33	0.46	0.59	0.65	0.75	0.88	1.08
1.05	<b>0.69</b>	0.30	0.43	0.56	0.62	0.72	0.85	1.05
1.02	<b>0.70</b>	0.27	0.40	0.54	0.59	0.69	0.82	1.02
0.99	<b>0.71</b>	0.24	0.37	0.51	0.57	0.66	0.79	0.99
0.96	<b>0.72</b>	0.21	0.34	0.48	0.54	0.64	0.76	0.96
0.94	<b>0.73</b>	0.19	0.32	0.45	0.51	0.61	0.73	0.94
0.91	<b>0.74</b>	0.16	0.29	0.42	0.48	0.58	0.71	0.91
0.88	<b>0.75</b>	0.13	0.26	0.40	0.46	0.55	0.68	0.88
0.86	<b>0.76</b>	0.11	0.24	0.37	0.43	0.53	0.65	0.86
0.83	<b>0.77</b>	0.08	0.21	0.34	0.40	0.50	0.63	0.83
0.80	<b>0.78</b>	0.05	0.18	0.32	0.38	0.47	0.60	0.80
0.78	<b>0.79</b>	0.03	0.16	0.29	0.35	0.45	0.57	0.78
0.75	<b>0.80</b>	-	0.13	0.27	0.32	0.42	0.55	0.75
0.72	<b>0.81</b>	-	0.10	0.24	0.30	0.40	0.52	0.72
0.70	<b>0.82</b>	-	0.08	0.21	0.27	0.37	0.49	0.70
0.67	<b>0.83</b>	-	0.05	0.19	0.25	0.34	0.47	0.67
0.65	<b>0.84</b>	-	0.03	0.16	0.22	0.32	0.44	0.65
0.62	<b>0.85</b>	-	-	0.14	0.19	0.29	0.42	0.62
0.59	<b>0.86</b>	-	-	0.11	<b>0.17</b>	0.26	0.39	0.59
0.57	<b>0.87</b>	-	-	0.08	0.14	0.24	0.36	0.57
0.54	<b>0.88</b>	-	-	0.06	0.11	0.21	0.34	0.54
0.51	<b>0.89</b>	-	-	0.03	0.09	0.18	0.31	0.51
0.48	<b>0.90</b>	-	-	-	0.06	0.16	0.28	0.48
0.46	<b>0.91</b>	-	-	-	0.03	0.13	0.25	0.46
0.43	<b>0.92</b>	-	-	-	-	0.10	0.22	0.43
0.40	<b>0.93</b>	-	-	-	-	0.07	0.19	0.40
0.36	<b>0.94</b>	-	-	-	-	0.03	0.16	0.36
0.33	<b>0.95</b>	-	-	-	-	-	0.13	0.33
0.29	<b>0.96</b>	-	-	-	-	-	0.09	0.29

## Determination of required capacitor rating from the utility company's invoice

The required capacitor power rating can be determined relatively easily and accurately from the power supply company's monthly invoice. If power consumption is constant throughout the year, the annual electricity consumption or any desired monthly invoice (but not for the month in which the annual shutdown occurs), may be taken as a basis. If seasonal variations are apparent, an invoice from the "high season" must of course be selected. If regular and off-peak tariffs are measured separately, usually the regular tariffs are used for calculation purposes. It can be assumed that the capacitor power rating derived will be adequate to cover the reactive current circulating at night. In special cases, however, where the less expensive off-peak power is used predominantly, the off-peak consumption may not be neglected.

### Kilowatt-hour tariff

With the kilowatt-hour tariff

- Max. potential demand
- Active energy
- Reactive energy are invoiced as separate items.

With most power supply contracts, no charge is made for reactive energy if its magnitude is up to 50% of the active energy. Only amounts that exceed this figure must be paid for. This corresponds approximately to a  $\cos \varphi$  of 0.9. It is recommended, however, to use a slightly higher figure, e.g. 0.92, for calculation purposes, in order to have a small margin in reserve in the capacitor power rating.

Specimen calculation using figures from the utility company's invoice:

• Active power	99	kW	$\tan \varphi = \frac{\text{active energy (regular)} \ 19840 \ \text{kVAh}}{\text{reactive energy (regular)} \ 17820 \ \text{kWh}} = 1.11$
• Active energy (regular tariff)	17820	kWh	
• Reactive tariff (off-peak)	19840	kVArh	

The actual value of  $\cos \varphi$  can now be obtained from Table 2, since the calculated  $\tan \varphi$  of 1.11 corresponds to a  $\cos \varphi_1$  of 0.67.

A factor  $f$  of **0.68** is then obtained from Table 2 to produce a **desired  $\cos \varphi_2 = 0.92$** .

The required capacitor power rating is calculated from:

Active power  $\times$  factor  $f$   $99 \ \text{kW} \cdot 0.68 = 67.32 \ \text{kVAr}$

In this case a capacitor rating of 75 kVAr must be selected. If a possible future expansion of the facility is also to be taken into account, then a somewhat larger capacitor, (e.g. 100 kVAr) could also be selected.

### Demand tariff

In this case the utility company bases its invoice on the maximum amount of power drawn by the user during the given month. If it is not the active power but instead the apparent power, which is measured for this purpose, it is advisable to select a capacitor power rating that will achieve a  $\cos \varphi$  of 1.

Specimen calculation using figures from the utility company's invoice:

• Maximum active power	104 kW	$\frac{\text{max. active power}}{\cos \varphi} = \frac{104 \ \text{kW}}{0.62} = 168 \ \text{kVA}$
• $\cos \varphi_1$	0.62	

From Table 2, with an uncorrected  $\cos \varphi_1 = 0.62$  and a desired  $\cos \varphi_2 = 1$ , a factor  $f$  of 1.27 is read off.

The required capacitor power rating can then be calculated:

Active power  $\times$  factor  $f$   $104 \ \text{kW} \cdot 1.27 = 132.08 \ \text{kVAr}$

For this duty a VAR controller with a capacitor power rating of 150 to 175 kVAr is arranged as a switched variable bank.

## Single power factor correction for transformers

The utility company regulations for the allowable size of capacitors permanently connected to a transformer are according to region. Before installing a power factor correction system of this type, it is therefore advisable to consult the utility company concerned. The modern design of transformer features core laminations that only require a small amount of power for reversal of magnetisation. If the capacitor power rating is too high, overvoltage conditions may occur during no-load operation.

Capacitors with built-in fuse switches are well suited for this duty. If capacitors with fuse switches are connected directly to the transformer terminals, the designer should be aware of the fact that the lines to the capacitor are dimensioned for the full short-circuit power.

**Table 3: Approximate capacitor ratings for individual power factor correction of transformers (German Electricity Association (VDEW))**

Transformer nominal rating in kVA	Capacitor power rating in kVAr
100 - 160	2.5
200 - 250	5
315 - 400	7.5
500 - 630	12.5
800	15
1000	20
1250	25
1600	35
2000	40

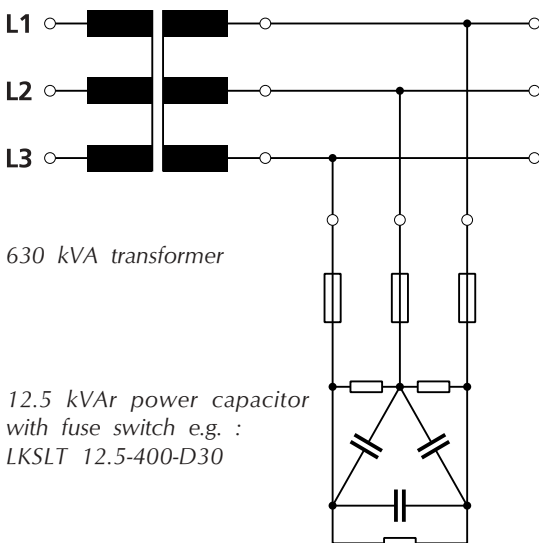

The capacitor with fuse switch can be directly connected to the terminals of the transformer. This means that the lines to the capacitor must be dimensioned for the full short-circuit power.

**Note:** The fuse switches are operated under purely capacitive load. They must therefore never be withdrawn when under load or dangerous arcing may otherwise occur!

If it is necessary to disconnect the capacitor even when the transformer is switched on, a power capacitor with an automatic circuit breaker must be used.

**Fig. 16:** Typical transformer with permanent power factor correction

## Single power factor correction for motors

The capacitor power rating should be some 90% of the motor apparent power when running under no-load conditions.

Required capacitor power rating:

$$Q_C = 0.9 \cdot \sqrt{3} \cdot V \cdot I_0$$

[VAr]                      [V] [A]

$I_0$  = no-load motor current

This produces a power factor of about 0.9 under full load and 0.95 - 0.98 under no-load conditions. The German Electricity Association (VDEW) recommends the approximate capacitor ratings in Table 4 below for induction motors running at 1500 min<sup>-1</sup>. The values given in the table should be increased by 5% for motors running at 1000 min<sup>-1</sup>, or by 15% for motors running at 750 min<sup>-1</sup>.

**Table 4: Approximate values specified by the VDEW for individual power factor correction of motors**

Motor nominal rating in kW			Capacitor power rating in kVAr
1	to	1.9	0.5
2	to	2.9	1
3	to	3.9	1.5
4	to	4.9	2
5	to	5.9	2.5
6	to	7.9	3
8	to	10.9	4
11	to	13.9	5
14	to	17.9	6
18	to	21.9	7.5
22	to	29.9	10
30	to	39.9	approx. 40% of motor power
40	or	above	approx. 35% of motor power

**Note:** In the case of electrical machines with single power factor correction where the capacitor is directly connected to the motor terminals, the capacitor power rating must on no account be overdimensioned. This applies in particular if the motor has a high centrifugal mass with the tendency to run on after it is switched off. The shunt capacitor can then excite the machine to act as a generator, producing dangerous overvoltages. These can cause damage not only to the capacitor but also to the motor.

## Single power factor correction for motors

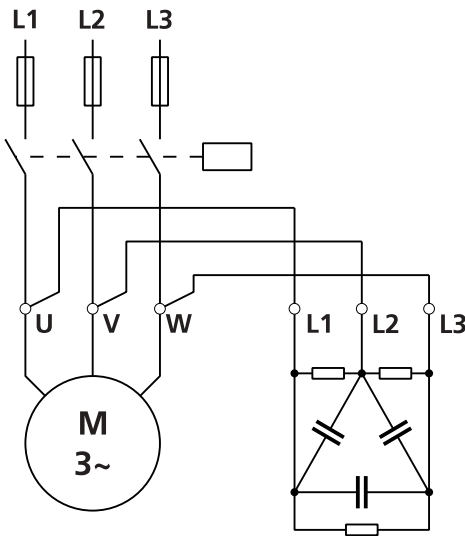

25 kW induction motor running at 1500 min<sup>-1</sup> 10 kVAr power capacitor e.g.: LKN 10-400-D32

**Fig. 17:** Typical permanently installed power factor correction for a motor

In the simplest case, the capacitor is directly connected to the motor terminals. There is no need to provide special overcurrent protection for the capacitor because the protection of the motor also covers the capacitor. If a motor protective switch is installed, it is advisable to readjust the current trip setting to a lower value.

Reduced trip current:

$$I_{th} = \frac{\cos \varphi_1}{\cos \varphi_2} \cdot I_N$$

- $I_{th}$  = new current trip setting (in A)
- $I_N$  = motor nominal current as per nameplate (in A)
- $\cos \varphi_1 = \cos \varphi$  as per nameplate
- $\cos \varphi_2 = \cos \varphi$  with power factor correction (approx. 0.95)

The capacitor discharges directly through the low ohmic resistance of the motor windings. Special discharge resistors are therefore not absolutely necessary.

## Single power factor correction for elevator and hoist motors

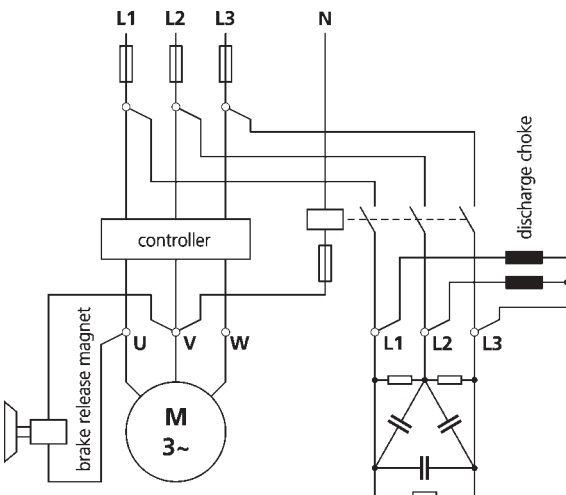

**Fig. 18:** Elevator motor with own capacitor switching contactor and rapid discharge facility

Elevator and hoist motors work with safety devices, such as the brake release magnet, which actuates a quick-acting brake if power failure occurs. If the capacitor were directly in parallel with the motor, its residual energy could delay this emergency braking or even prevent it from being effective. The capacitors must therefore only be connected to the circuit before the switchgear. A separate contactor should be provided for the capacitor with its own rapid discharge facility, effected either by means of a discharge choke connected directly to the capacitor or with rapid discharge resistors switched in by the capacitor contactor.

An interlock must be incorporated in the control system to prevent the capacitor being switched in again before the discharge time has expired.

Because of the frequency of switching and the resultant wear and tear of the contactors, it is advisable to use capacitor sections with solid-state switches. These switch the capacitors in and out at zero current, response times in the order of milliseconds being attainable.



## Star-delta switch

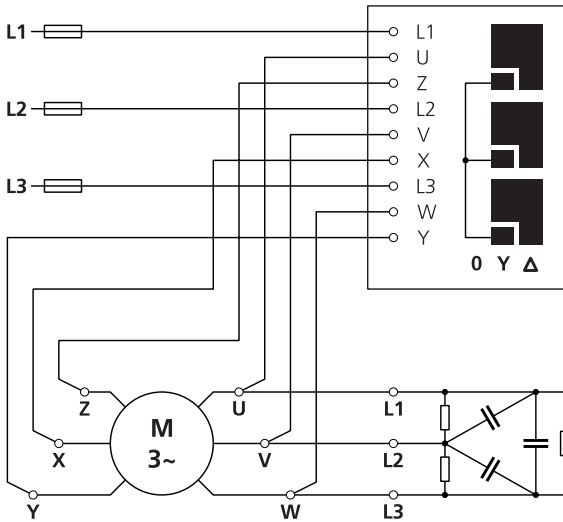

**Fig. 19:** Manually operated star-delta switch, special version for motors with single power factor correction

If manually operated star-delta switches are to be used with three-phase power capacitors, a version designed to control motors with single power factor correction must be selected.

The contact bridges must be designed so that, while switching from star to delta, no rapid reclosing occurs to switch the capacitor into "phase opposition". This would involve excessively high recharging currents which could damage not only the capacitor but also the switch.

When the switch is in the OFF position (motor switched off), the neutral bridge must not be closed, so that the capacitor is not short-circuited.

## Star-delta contactor groups

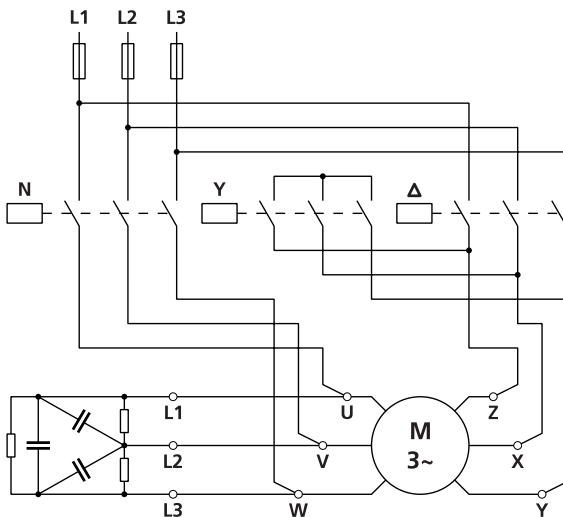
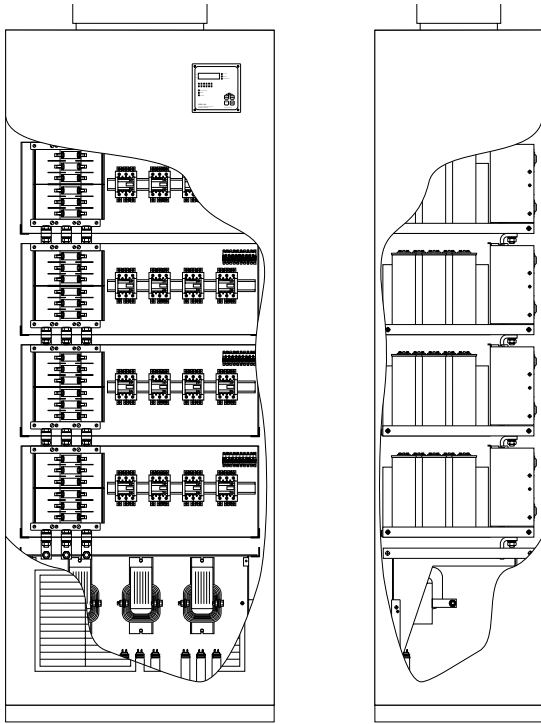

**Fig. 20:** Motor with single power factor correction and star-delta contactor

With star-delta contactor groups it must be ensured, just as with star-delta switches, that no rapid disconnection occurs during the changeover from star to delta, i.e. the line contactor must remain energised. When the motor is switched off, the star bridge must be open. The capacitor can be connected to the load side of the line contactor or to the terminals U, V and W of the motor, not however to its terminals X, Y and Z, since these are short-circuited by the star bridge.

**Note:** The capacitor power rating must on no account be overdimensioned. This applies in particular if the motor has a high centrifugal mass with the tendency to run on after it is switched off. The shunt capacitor can then excite the machine to act as a generator, producing dangerous overvoltages. For this reason when star-delta starting is used, the star bridge should not remain closed when the switch is OFF. If the machine is excited as a generator with the star connection made, even higher voltages than those with the delta connection are to be expected.

## Power factor correction systems



**Fig. 21:** Typical modular design of a power factor correction system

Power factor correction systems consist of the following components:

- reactive power control relay
- banks of capacitors switched in and out by contactors or solid-state switches
- filter reactors, if required
- audiofrequency suppression circuits, if required
- group overcurrent protection
- a thermostatically-controlled cooling fan, if filter reactors installed,

The components can either be assembled on a mounting plate or, if a modular system capable of being extended at a later date is called for, in a control cabinet.

Power factor correction systems are installed in power distribution networks where the reactive power demand fluctuates constantly. The capacitor power rating is divided into several sections that can be switched in and out by an automatic reactive power control relay via contactors or steady-state switches to suit load conditions.

A centralised power factor correction system is easy to monitor. State-of-the-art reactive power control relays enable switch status,  $\cos \phi$ , active current, reactor current and the harmonics present in the network to be monitored continuously. Usually the total capacitor power rating can be less than with single power factor correction since the coincidence factor can be taken into account when designing the complete industrial facility. Optimum use is thus made of the installed capacitor power rating.

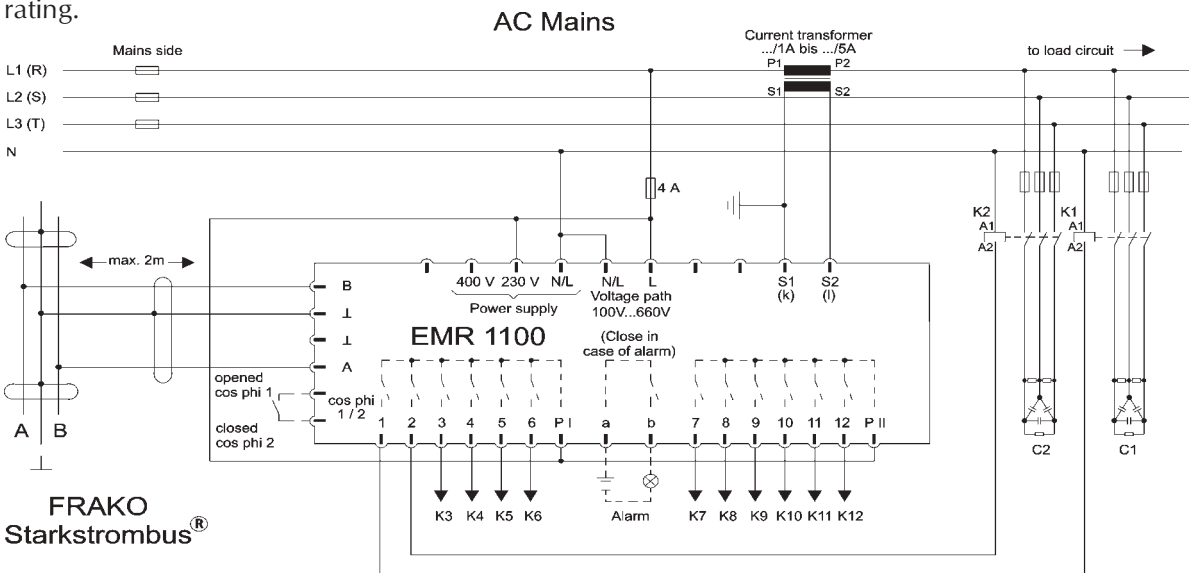

**Fig. 22:** Typical circuit with a power factor correction system

## Power capacitors

FRAKO type LKT series power capacitors are PCB-free. They are manufactured with a self-healing dielectric. If this is punctured due to overload conditions (e.g. overvoltage), the capacitor element effectively repairs itself. As an additional protective measure, every capacitor has a reliable internal fuse which responds to excessive pressure.

Three key factors are important in the operation of power capacitors in power distribution systems:

- **high overload capacity,**
- **long life expectancy**
- **safe reaction at overload and during possible breakdowns**

Power capacitors are components with a very high power density. **Nowadays a reactive power of some 15 kVAr being accommodated in a volume of one liter.** This is achieved by attaining a very low dissipation factor and a high degree of utilisation of the dielectric. To achieve a long service life despite this high energy density, partial discharges (i.e. negligible electrical discharges within the dielectric material) must be suppressed.

## **Current-carrying capacity**

In power distribution systems where harmonics occur, the user has to expect overvoltages when resonances occur, and in particular higher current loads:

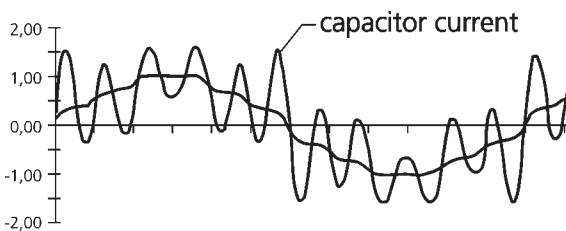

If, for example, about 7% of the 11th harmonic is present, then the voltage is 7% higher, but the effective level of the capacitor current is 1.33 times the capacitor nominal current! For this reason a high current-carrying capacity is even more important than the overvoltage capacity.

At a supply voltage of 400 V, FRAKO only uses power capacitors with a nominal voltage of at least 440 V. Their permissible current-carrying capacity amounts to:

- twice the nominal current at 400 V continuous and
- 300 times the nominal current for transient current peaks.

## **Voltage capacity**

FRAKO power capacitors have the following loading capacity as per VDE 0560, Part 41 and EN 60831-1 and -2 (German Association of Electrical Engineers Specification):

Nominal voltage		440 V	480 V	525 V	610 V
8 h	daily	484 V	528 V	578 V	671 V
30 min	daily	506 V	552 V	604 V	702 V
5 min		528 V	576 V	630 V	732 V
1 min		572 V	624 V	683 V	793 V

## Service life

Overvoltage, overheating and harmonics shorten the life expectancy of a capacitor. Only extreme cleanliness in the production process and maximum purity of the materials used prevent a worsening of the loss factor and thus a reduction in dielectric strength and current-carrying capacity. Voltage endurance tests under very severe test conditions (1.5 x nominal voltage, 60 °C ambient temperature, high harmonic distortion) are regularly carried out on capacitors from the production line: The loss of capacitance is far less than 1%, the failure rate is infinitesimal and the dissipation factors remain stable at a very low level.

The stated life expectancy of our power capacitors is at least 50,000 hours with a failure rate maximum 3%. However, we register all returned units and all cases of failure made known to us! According to these statistics, the failure rate amounts to less than 200 ppm per year, corresponding to a failure rate of far less than 3 % in 200,000 operating hours!

## Safety characteristics at the end of the capacitor's service life

An important safety consideration is to ensure with the maximum possible certainty that, in the event of the capacitor being overloaded and at the end of its service life, it cannot be destroyed. This safety feature is only offered by modern power capacitors with a built-in interrupting device which

- is activated by excessive internal over pressure,
- disconnects the capacitor from the power supply and
- thus prevents the capacitor can being destroyed.

Because of the high power density of modern capacitors, FRAKO uses the most sophisticated and effective interrupting device, the flanged diaphragm lid.

The aluminum can and lid are rolled together and bonded with an elastic sealant. The average number of power capacitors returned to the manufacturer in recent years due to this joint leaking is about 10 ppm, i.e. a reject rate of 0.001 percent!

The flanged diaphragm lid fitted in this way supports the capacitor terminals securely in position during normal operation. If an internal over pressure develops inside the capacitor and reaches about 3 bar, the diaphragm lid bulges outwards, thus displacing the terminals axially by more than 10 mm at a pressure well below the critical figure. In most cases the internal leads break cleanly at a displacement of about 5 mm, thus disconnecting the element from the power supply without restriking. Manufacturing quality for this over pressure interrupting device is monitored at FRAKO by type testing and random sample tests. The test conditions are as set out in VDE 0560 Part 41 and the publication IEC 831.

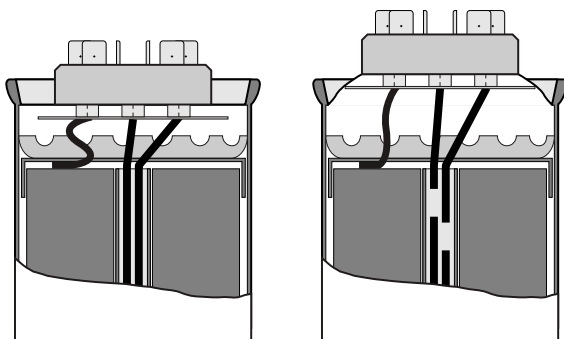

FRAKO power capacitors therefore offer a high degree of safety when overloaded and at the end of their service life.

**Fig. 23:** Sectional view through a FRAKO power capacitor showing the interrupting device under excess internal over pressure.

## Reactive power control relays



**Fig. 24:** Type EMR 1100

### Key features in detail:

- **Accurate measurement of cos phi even in networks badly affected by harmonics with 0,02 A to 5 A in the measurement circuit.** Exact measurement of the power factor of the fundamental oscillation, even when the currents measured are very small, means that high precision is achieved in the cos phi control loop.
- **Adherence to the set cos phi as minimum value, while at the same time avoiding overcorrection under low-load conditions.** These seemingly contradictory properties are achieved by means of the patented "bent" control characteristic, which ensures that under normal network loading the power factor is corrected to maintain its desired value, but when the loading is low, overcorrection (often a problem with conventional systems) does not occur.
- **Measurement and monitoring of harmonics in low voltage networks** (5th, 7th, 11th and 13th harmonics). This monitoring function keeps the user permanently informed about the network power quality and warnings are given in good time whenever critical parameters go beyond set limits. This enables distortions in the power distribution system and user circuits to be combatted at an early stage by taking appropriate measures.
- **Overcurrent trip function for excessive r.m.s. current input of power factor correction systems with out reactors.** In addition to providing overload protection for PFC systems without reactors, the function also protects the complete electrical system against harmonic resonance. Disconnection is carried out if the set limit is exceeded for more than 75 seconds. Overcurrent disconnection is quicker to act than the protective device at the distribution board, which only affords protection against short circuits because of the high current-carrying capacity of the capacitors.
- **The speed of response is dependent on the power demand.** High load fluctuations are responded to quickly, while low load fluctuations are compensated for more slowly. This ensures that only completely discharged capacitor elements are switched into the network. **Selective switching in relation to the power demand with the least possible switchings - cyclic control for all stages of equal importance.**
- This combination of control characteristics results in the lowest possible number of switching operations, thus minimising wear and tear and contributing to a longer service life for the power factor correction system.

FRAKO reactive power control relays types EMR 1100, RM 9612 and RM 9606 use microprocessor technology to perform complex management tasks going way beyond the control of the power factor itself to a given cos phi setpoint. Their innovative control characteristics meets all the requirements of present-day industrial power supply networks, giving these control relays universal applicability.

Their high accuracy and sensitivity even in networks badly affected by harmonics are worthy of mention, as is their ability to master continuous or sporadic reverse flow of power in networks with in-plant generators.

All components of the power factor correction system are carefully managed by these control relays and are protected from overloads. This results in the life expectancy of the complete system being considerably extended.

- At the same time critical network constellations are avoided by adjusting the capacitor power rating quickly and accurately to meet demands when heavy load changes occur. This contrasts with the step-by-step process.
- When correcting for large reductions in load, a prolonged overcorrection of idling transformers is prevented.
- In networks with harmonic distortion, attenuation of the harmonic currents by the filter circuits is ensured in the shortest possible time. This is a reliable means of preventing the maximum permissible level of harmonic distortion being exceeded when a current converter is subjected to heavy load changes.
- **No-volt and zero-current release.** This safety function disconnects the power factor correction system from the power supply if there is a break in the voltage or current measurement circuit. This precaution is to prevent violent surges, such as the system with its entire power demand being switched into the idling transformer following a transient interruption of voltage. After the voltage is reestablished, the control relay switches in the appropriate number of capacitor stages again to suit the power demand.
- **Power factor correction for systems with plant generators operating in parallel with the utility company's supply network and returning active energy to that network.** The control relays are equipped with a 4-quadrant energy element for this function. In addition, various different control characteristic curves can be selected for the import and export of active energy. This ensures that when electrical energy is being imported no overcorrection occurs and when exporting energy no reactive current is drawn. Only this combination of control characteristics can ensure that no costs are incurred for reactive current when energy is being exported for prolonged periods of time.
- **Fixed amounts of capacitance for power factor correction independent of load.** Fixed numbers of switched-in capacitor stages can be set that are not integrated in the control process but remain permanently switched in for as long as the operating voltage is applied to the control relay. All safety functions, such as the no-volt and zero-current release plus the overcurrent trip are also effective for the fixed stages that have been programmed.
- **Two control programs which work separately, with changeover activated by an external contact.** Two programs can be assigned different  $\cos \phi$  setpoints and different control characteristic curves. This enables certain requirements by the utility company to be complied with. For example greater power factor correction during the day and less at night.

### Start-up and operation

- **Automatic adjustment to the power supply network and the power factor correction system to be controlled.** Start-up is greatly simplified by the fact that the control relay performs this function itself. The choice of the phase in which the current transformer is fitted and the polarity with which the current transformer is connected to the control relay is left to the installer. Phase angle and direction of power flow are determined by the control relay in the course of calibration. At the same time it measures the power ratings of the capacitor stages to which it is connected and disables those control relay output contacts that are not in use.

If the installation is faulty, the control relay gives precise information on what is lacking to ensure correct operation.

In the case of a subsequent increase in the rating of the power factor correction system, calibration should be repeated, so that the new capacitor stages can be immediately integrated in the control process. If this is not carried out the relay identifies them after several days and integrates them automatically.

When the relay identifies a defect stage during operation it separates it from the control process and marks it.

- **Indication and messages.** All variables measured by the control relay can be shown in the display. When in operation, the display shows the actual  $\cos \phi$  measured at the location where the instrument transformer is installed. The display can also be switched over to show the following measured variables:
  - Apparent, active and reactive currents of the phase conductor that is monitored.
  - Relative harmonic levels of the 5th, 7th, 11th and 13th harmonics in relation to the voltage measured in the connected circuit.
  - The peaks that occur when set limits are exceeded (overcurrent, harmonics and  $\cos \phi$ ) can also be accessed and displayed.
- **Counting and display of the switching cycles of each control contact and appropriate messaging when the set limit has been reached.** Contactors are subject to considerable stress when switching capacitive loads. Chattering switching contacts result in high recharging currents in the capacitors and severe wear and tear of the switching contacts themselves. Replacing the switching contactors in good time can considerably prolong the service life of the power factor correction system. The reactive power control relay indicates the optimum point in time when the switching contactors should be replaced and thus helps to cut costs. For preventive maintenance purposes, the user can display the cumulative total of switching cycles for each individual capacitor element.

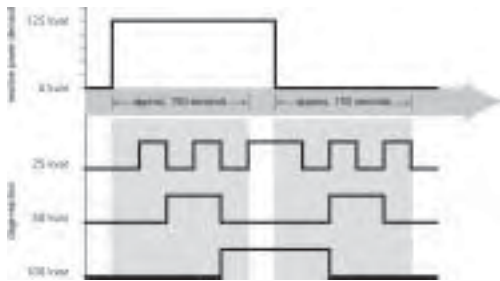

**Fig. 25:** Control process with a classical reactive power control relay using step-by-step switching

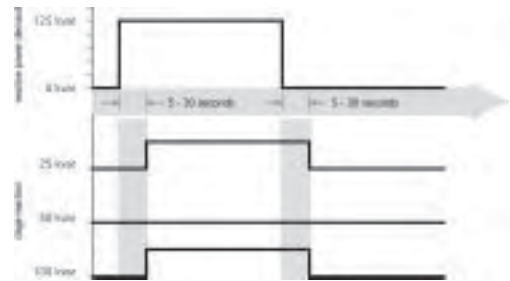

**Fig. 26:** Control process with state-of-the-art RM 9606, RM9612 and EMR 1100 FRAKO reactive power control relays

<u>Indicated parameters, messages and alarms</u>	<u>Information</u>	<u>Communicated via</u>	<u>Alarm contact</u>
Actual $\cos \phi$	indicator	display	
Apparent, active, reactive current (true values)	indicator	display	
Harmonics (5th, 7th, 11th, 13th)	indicator	display	
Harmonics (5th, 7th, 11th, 13th)	alarm	display / LED	closes
Overcurrent (adjustable from $1.05 I_{nom}$ to $3.0 I_{nom}$ )	alarm	display / LED	closes
Actual $\cos \phi$ outside characteristic curve indication of deficiency in capacitor rating	alarm	display / LED	closes (can be disabled)
Number of switching cycles per control contact	indicator	display	
Set limit for number of switching cycles exceeded	alarm	display / LED	closes
No measured voltage	alarm	display	closes
No measured current	message	display	
Control relay detects no capacitance at any control contact	alarm	display	closes
Capacitor stages switched in	indicator	LED	
No operating voltage			closes

## Current transformer

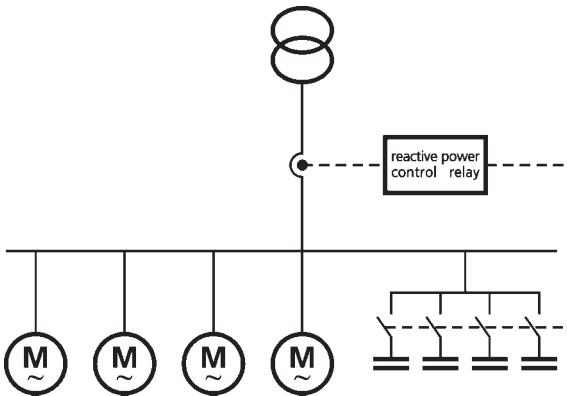

**Fig. 27: Correctly** installed current transformer registers load current **and** capacitor current

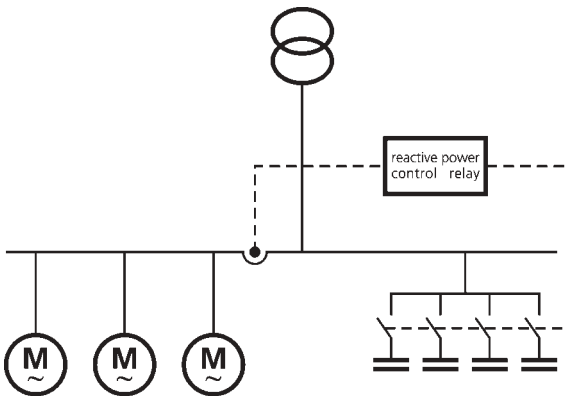

**Fig. 28: Incorrect!** The current transformer only registers the load current: the capacitor bank is switched in but not out again. Automatic calibration of the reactive power control relay is not possible!

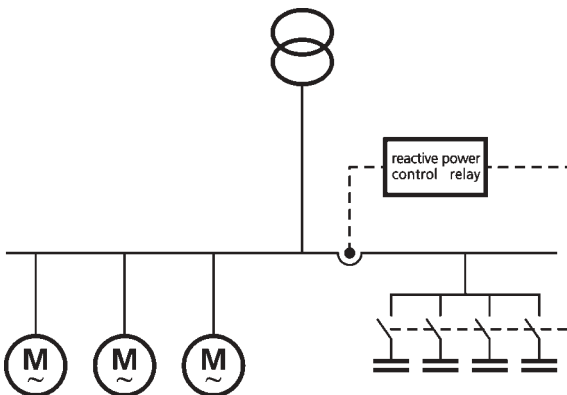

**Fig. 29: Incorrect!** The current transformer only registers the capacitor current: the capacitor is not switched in. The reactive power control relay gives the message "I = 0" (no current in transformer circuit)!

A current transformer is necessary to operate power factor correction systems. This is not included in the scope of supply, but can be provided with the system after clarification of user requirements. The primary current in the transformer is determined by the user's current input, i.e. this unit is designed for the maximum current loading or the installed load connected to the power transformer. The reactive power control relay current circuit is designed for a .../ 1 to .../5 A current transformer rated at 5 VA, Class 3. If ammeters are installed in series with the control relay, the rating of the current transformer must be increased to suit. The internal power consumption in the control relay current circuit amounts to some 1.8 VA for a current transformer of nominal current 5 A.

If further instruments need to be powered from the same current transformer, this must be taken into account when specifying its rating.

Losses also occur in the current transformer wiring, and these must also be taken into account if there are long lengths of cable between the current transformer and the reactive power control relay.

### Power losses in copper conductors

from the current transformer with a secondary current of 5 A:

Cross section in mm <sup>2</sup>	Losses per 1 m of two-wire line in VA
2.5	0.36
4.0	0.22
6.0	0.15
10.0	0.09

**Note:** The current transformer must be installed in one of the three phases so that the entire current to the consumers requiring power factor correction and the capacitor current flow through it (as shown in the diagrams on the left). The terminal P1 (K) is connected to the supply side, terminal P2 (L) to the consumer side.

**Caution:** When the primary circuit is broken, voltage surges occur which could destroy the current transformer. Therefore before breaking the current transformer circuit, the terminals S1 (k) and S2 (l) must be short-circuited before the transformer circuit is broken.



## Fuses and Cables

When installation work is carried out, the regulations VDE 0100, VDE 0105, (German Association of Electrical Engineers), the general guidelines of the VDEW (German Electricity Association) and the conditions of supply of the utility company concerned must be complied with. VDE 0560 Part 41 states that capacitor units must be suitable for a continuous r.m.s. current of 1.3 times the current that is drawn at the sinusoidal nominal voltage and nominal frequency. If the capacitance tolerance of  $1.1 \times C_N$  is also taken into account, the maximum allowable current can reach values of up to  $1.38 \times I_N$ . This overload capability together with the high in-rush current to the capacitors must be taken into account when designing protective devices and cable cross-sections.

**Note:** FRAKO power capacitors offer an current load capacity of  $2 \times I_N$  at 400V.

**Table 5:** Fuses and supply cable cross-sections according to VDE 0100, Part 430, layout method C.

Power in kVAr	230V / 50 Hz			400V / 50 Hz			525V / 50 Hz		
	Current in A	Fuse in A	Cross-section in mm <sup>2</sup>	Current in A	Fuse in A	Cross-section in mm <sup>2</sup>	Current in A	Fuse in A	Cross-section in mm <sup>2</sup>
2.5	6.3	10	4 x 1.5	3.6	10	4 x 1.5	2.7	10	4 x 1.5
5	12.6	20	4 x 2.5	7.2	10	4 x 1.5	5.5	10	4 x 1.5
6.25	15.7	25	4 x 4	9.0	16	4 x 2.5	6.9	10	4 x 1.5
7.5	18.8	35	4 x 6	10.8	16	4 x 2.5	8.2	16	4 x 2.5
10	25.1	35	4 x 6	14.4	20	4 x 2.5	11.0	16	4 x 2.5
12.5	31.4	50	4 x 10	18.0	25	4 x 4	13.7	20	4 x 2.5
15	37.7	63	4 x 16	21.7	35	4 x 6	16.5	25	4 x 4
17.5	43.9	63	4 x 16	25.3	35	4 x 6	19.2	35	4 x 6
20	50.2	80	3 x 25/16	28.9	50	4 x 10	22.0	35	4 x 6
25	62.8	100	3 x 35/16	36.1	50	4 x 10	27.5	50	4 x 10
27.5	69.0	100	3 x 35/16	39.7	63	4 x 16	30.2	50	4 x 10
30	75.3	125	3 x 50/25	43.3	63	4 x 16	33.0	50	4 x 10
31.25	78.4	125	3 x 50/25	45.1	63	4 x 16	34.4	50	4 x 10
37.5	94.1	160	3 x 70/35	54.1	80	3 x 25/16	41.2	63	4 x 16
40	100.4	160	3 x 70/35	57.7	80	3 x 25/16	44.0	63	4 x 16
43.75	109.8	160	3 x 70/35	63.1	100	3 x 35/16	48.1	80	3 x 25/16
45	113.0	160	3 x 70/35	65.0	100	3 x 35/16	49.5	80	3 x 25/16
50	125.5	200	3 x 95/50	72.2	100	3 x 35/16	55.0	80	3 x 25/16
52.5	131.8	200	3 x 95/50	75.8	125	3 x 50/25	57.7	80	3 x 25/16
60	150.6	250	3 x 120/70	86.6	125	3 x 50/25	66.0	100	3 x 35/16
62.5	156.9	250	3 x 120/70	90.2	125	3 x 50/25	68.7	100	3 x 35/16
67.5	169.4	250	3 x 120/70	97.4	160	3 x 70/35	74.2	125	3 x 50/25
68.75	172.6	250	3 x 120/70	99.2	160	3 x 70/35	75.6	125	3 x 50/25
75	188.3	315	3 x 185/95	108.3	160	3 x 70/35	82.5	125	3 x 50/25
87.5	219.6	315	3 x 185/95	126.3	200	3 x 95/50	96.2	160	3 x 70/35
93.75	235.3	400	2 x 3 x 95/50	135.3	200	3 x 95/50	103.1	160	3 x 70/35
100	251.0	400	2 x 3 x 95/50	144.3	200	3 x 95/50	110.0	160	3 x 70/35
112.5	282.4	400	2 x 3 x 95/50	162.4	250	3 x 120/70	123.7	200	3 x 95/50
120	301.2	500	2 x 3 x 120/70	173.2	250	3 x 120/70	132.0	200	3 x 95/50
125	313.8	500	2 x 3 x 120/70	180.4	250	3 x 120/70	137.5	200	3 x 95/50
150	376.5	630	2 x 3 x 185/95	216.5	315	3 x 185/95	165.0	250	3 x 120/70
175	439.3	630	2 x 3 x 185/95	252.6	400	2 x 3 x 95/50	192.5	315	3 x 185/95
200	502.0	800	2 x 3 x 240/120	288.7	400	2 x 3 x 95/50	219.9	315	3 x 185/95
225	-	-	-	324.8	500	2 x 3 x 120/70	247.4	400	2 x 3 x 95/50
250	-	-	-	360.8	500	2 x 3 x 120/70	274.9	400	2 x 3 x 95/50
275	-	-	-	396.9	630	2 x 3 x 185/95	302.4	500	2 x 3 x 120/70
300	-	-	-	433.0	630	2 x 3 x 185/95	329.9	500	2 x 3 x 120/70
350	-	-	-	505.2	800	2 x 3 x 240/120	384.9	630	2 x 3 x 185/95
375	-	-	-	541.3	800	2 x 3 x 240/120	412.4	630	2 x 3 x 185/95
400	-	-	-	577.4	800	2 x 3 x 240/120	439.9	630	2 x 3 x 185/95

Table 6: Outer diameters of cables and conductors

Conductor cross-section in mm <sup>2</sup>	NYM Ø in mm	NYY Ø in mm	NYCY/NYCWX Ø in mm	H05VV-F Ø in mm	H07RN-F Ø in mm
2 x 1.5	9.0	11.0	12.0	10.5	11.5
2 x 2.5	10.5	13.0	14.0	12.5	13.5
3 x 1.5	10.0	11.0	13.0	11.0	12.5
3 x 2.5	11.0	13.0	14.0	13.0	14.5
3 x 4	12.5	15.0	16.0	-	16.0
3 x 6	14.0	16.0	17.0	-	20.0
3 x 10	17.0	19.0	18.0	-	25.5
3 x 16	20.0	21.0	21.0	-	29.0
4 x 1.5	10.5	13.0	14.0	12.5	13.5
4 x 2.5	12.0	14.0	15.0	14.0	15.5
4 x 4	14.0	16.0	17.0	-	18.0
4 x 6	15.0	17.0	18.0	-	22.0
4 x 10	18.0	20.0	20.0	-	28.0
4 x 16	23.0	23.0	23.0	-	32.0
4 x 25	27.5	27.0	28.0	-	37.0
4 x 35	31.0	30.0	29.0	-	42.0
4 x 50	-	35.0	34.0	-	48.0
4 x 70	-	40.0	37.0	-	54.0
4 x 95	-	45.0	42.0	-	60.0
4 x 120	-	50.0	47.0	-	-
4 x 150	-	53.0	52.0	-	-
4 x 185	-	60.0	60.0	-	-
4 x 240	-	71.0	70.0	-	-
5 x 1.5	11.0	13.5	15.0	13.5	15.0
5 x 2.5	13.0	15.0	17.0	15.5	17.0
5 x 4	15.0	16.5	18.0	-	19.0
5 x 6	18.0	19.0	20.0	-	24.0
5 x 10	20.0	21.0	-	-	30.0
5 x 16	24.0	23.0	-	35.0	-
7 x 1.5	-	13.5	-	-	-
10 x 1.5	-	17.0	-	-	-
12 x 1.5	-	17.5	-	-	-
14 x 1.5	-	18.0	-	-	-
16 x 1.5	-	19.0	-	-	-
24 x 1.5	-	23.0	-	-	-

NYM Light plastic-sheathed cable

NYY Cable with plastic sheath

NYCY Cable with concentric conductor and plastic sheath

NYCWX Cable with concentric, waveconal conductor and plastic sheath

H05VV-F Ordinary rubber-sheathed flexible cable (NLH, NMH)

H07RN-F Heavy rubber-sheathed flexible cable (NSH)

**Table 7: Cable entry with cable screw connections**

Metric thread	Pg	Cable outer diameter in mm	Knockout diameter
M 16 x 1.5	11	6.5 - 10.5	19.0
-	13.5	8.0 - 12.5	21.0
M 20 x 1.5	16	10.0 - 15.0	23.0
M 25 x 1.5	21	12.0 - 20.0	29.0
M 32 x 1.5	29	19.0 - 26.5	38.0
M 40 x 1.5	36	29.0 - 34.0	48.0
-	42	34.0 - 41.0	55.0
M 50 x 1.5	48	40.0 - 45.0	60.0

## Protection

The standard EN 60529 specifies the degree of enclosure protection for electrical equipment by means of two letters and a two digit number. The letters IP stand for "International Protection" while the first and second numbers specify the protection against solid objects and liquids, respectively. The following are the most frequently encountered combinations:

**Table 8:** Common International protection specifications

Protection	Against accidental contact	Against solid objects	Against liquids
IP00	none	none	none
IP10	against accidental or inadvertent contact	over 50 mm Ø	none
IP20	with fingers and solid objects up to 80 mm long	over 20 mm Ø	none
IP30	with tools and wires > 2.5 mm in thickness	over 2.5 mm Ø	none
IP40	with wires or strips > 1 mm in thickness	over 1 mm Ø	none
IP41	with wires or strips > 1 mm in thickness	over 1 mm Ø	vertically drip-proof falling drops of water
IP54	complete protection	protected against dust	splash-proof from all directions
IP65	complete protection	totally protected against dust	jets of water from all directions

Capacitor power rating, single-phase:

$$Q_c = C \cdot V^2 \cdot 2 \cdot \pi \cdot f_n$$

Example: 83  $\mu$ F at 400 V / 50 Hz

$$0.000083 \cdot 400^2 \cdot 314.16 = 4.172 \text{ VAr} = 4.17 \text{ kVAr}$$

Capacitor power rating, three-phase:

$$Q_c = C \cdot 3 \cdot V^2 \cdot 2 \cdot \pi \cdot f_n$$

Example: 3 x 332  $\mu$ F at 400 V / 50 Hz

$$0.000332 \cdot 3 \cdot 400^2 \cdot 314.16 = 50 \text{ kVAr}$$

Capacitor phase current:

$$I = \frac{Q_c}{V \cdot \sqrt{3}} \quad \text{or} \quad Q_c = I \cdot V \cdot \sqrt{3}$$

Example: 25 kVAr at 400 V

$$25.000 / (400 \cdot 1.73) = 36 \text{ A}$$

Series resonance frequency ( $f_r$ ) and choke factor ( $p$ ) of capacitors with filter reactors:

$$f_r = f_n \cdot \sqrt{\frac{1}{p}} \quad \text{or} \quad p = \left( \frac{f_n}{f_r} \right)^2$$

Example:  $p = 0.07$  (7% choke) in 50 Hz network

$$f_r = 189 \text{ Hz}$$

Capacitor power rating, three-phase, with filter reactors:

$$Q_c = \frac{C \cdot 3 \cdot V^2 \cdot 2 \cdot \pi \cdot f_n}{1 - p}$$

Example: 3 x 332  $\mu$ F at 400 V / 50 Hz with choke factor  $p = 7\%$

$$0.000332 \cdot 3 \cdot 400^2 \cdot 314.16 / 1 - 0.07 = 53.8 \text{ kVAr}$$

Calculation of power factor  $\cos \varphi$  and  $\tan \varphi$ :

$$\cos \varphi = \frac{P}{S} \quad \text{or} \quad \cos \varphi = \sqrt{\frac{1}{1 + \tan^2 \varphi}} \quad \text{or} \quad \cos \varphi = \sqrt{\frac{1}{1 + \left( \frac{Q}{P} \right)^2}}$$

$$\tan \varphi = \frac{Q}{P} \quad \text{or} \quad \tan \varphi = \sqrt{\frac{1}{\cos^2 \varphi} - 1} \quad \text{or} \quad \tan \varphi = \sqrt{\frac{1}{\left( \frac{P}{S} \right)^2} - 1}$$

Where:

$V$  = voltage in V

$I$  = current in A

$f_n$  = network frequency in Hz

$f_r$  = series resonance frequency in Hz

$p$  = choke factor in %

$Q_c$  = capacitor power rating in VAr

$C$  = capacitance in F (farad)

$P$  = active power in W

$S$  = apparent power in VA

$Q$  = reactive power in VAr

## What are harmonics?

Modern low voltage networks increasingly have loads installed that draw non-sinusoidal currents from the power distribution system. These load currents cause voltage drops through the system impedances which distort the original sinusoidal supply voltage. Fourier analysis can be used to separate these superposed waveforms into the basic oscillation (supply frequency) and the individual harmonics. The frequencies of the harmonics are integral multiples of the basic oscillation and are denoted by the ordinal number "n" or "v" (Example: supply frequency = 50 Hz → 5th harmonic = 250 Hz).

Linear loads:

- ohmic resistances (resistance heaters, light bulbs, etc.)
- three-phase motors
- capacitors

Non-linear loads (harmonics generators):

- transformers and chokes
- electronic power converters
- rectifiers and converters, especially when controlling variable-speed induction motors
- induction and electric arc furnaces, welding equipment
- uninterruptable power supplies (UPS systems)
- single-phase switch-mode power supply units for modern electronic loads such as televisions, VCRs, computers, monitors, printers, telefax machines, ballasts, compact energy-saving lamps

**Fig. 30:** Network current and voltage superimposed with the following harmonics:

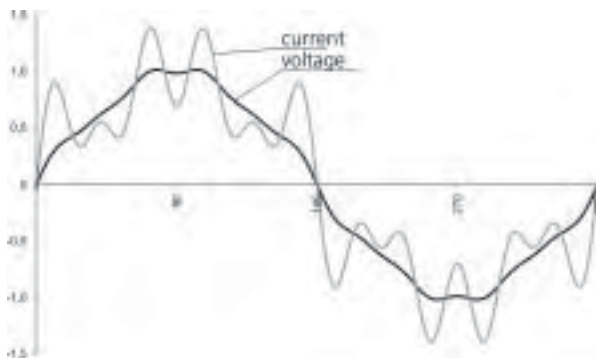

5 % of the 5th harmonic,  
4 % of the 7th harmonic and  
2.5 % of the 11th harmonic

Harmonics are produced not only in industrial networks but also increasingly in private households.

As a rule, those loads that draw non-sinusoidal current only give rise to odd harmonics, i.e. it is mainly the 3rd, 5th, 7th, 9th, 11th etc. harmonics that are present.

## How are harmonics produced?

- In a commercial facility's own low-voltage network, especially when variable-speed drives are installed.
- In every household: in every television, computer and in compact energy-saving lamps with electronic ballasts. The sheer number of these loads in the evenings with the currents in phase give rise to high levels of harmonics in some medium-voltage networks.

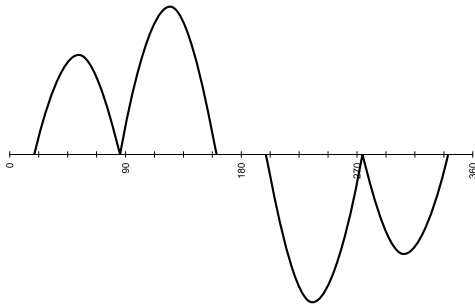

**Fig. 31:** Mains current of a converter for induction motors

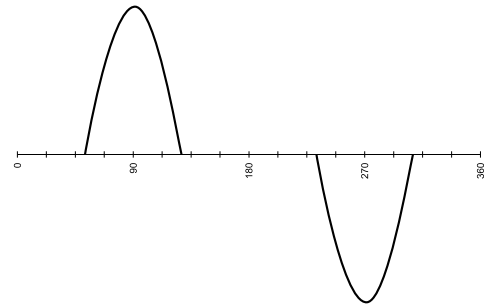

**Fig. 32:** Current of a power rectifier

## What is the level of these harmonics if no PFC system has yet been installed?

### a) In a facility's own low-voltage system:

depending on the power of the installed converters and rectifiers.

If, for example, a large six-pulse converter is installed in the network and its power rating is 50 % of the transformer nominal rating, this gives rise to about

- **4 % of the 5th harmonic (250 Hz) and**
- **3 % of the 7th harmonic (350 Hz)**

It is more usual, however, for several small converters that are not linked to each other to be installed in a network. The fact that the currents to the individual rectifiers are not all in phase means that the resulting harmonics voltages are less than in the above case.

If, for example, several rectifiers with a combined power of some 25 % of the transformer nominal rating are installed, this gives rise to some

- **1 -1.5 % of the 5th harmonic and**
- **0.7 - 1 % of the 7th harmonic.**

These are approximate values to help in the initial assessment of whether a choked power factor correction system needs to be installed.

### b) In the medium-voltage supply system:

Nowadays, most of these systems are affected predominantly by the apparatus in private households (mainly television sets) that produce harmonics. This is readily apparent when the daily curve for the 5th harmonic is examined:

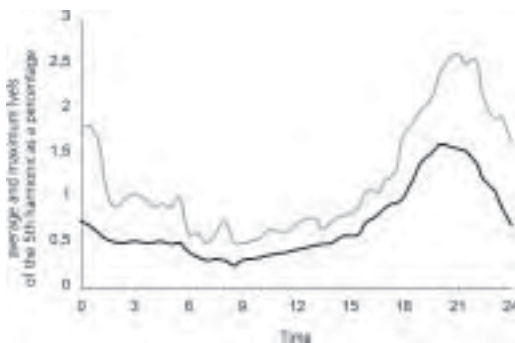

**Fig. 33:** Average and maximum levels of the 5th harmonic

The level of harmonics in the medium-voltage system of a municipal power supply with industrial loads on weekdays.

Average and maximum levels in a series of measurements carried out in 1985-1987 by the FGH electrical industry's research association, in Mannheim. It can be assumed with certainty that these levels are even higher today. The peak in the evenings is caused by the large number of television sets and other non-linear loads in private households.

In densely populated areas in the evenings, frequencies of about **4% 250 Hz and up to 1.5 % 350 Hz** can be superimposed on the medium-voltage supply system. The higher harmonics are usually negligible. Predictions of harmonics levels have only a limited accuracy!

## What effect does a power factor correction system have on a network with harmonics?

A power factor correction system with no choke forms an oscillatory circuit with reactive line impedances. The resonance frequency is given by a simple rule of thumb:

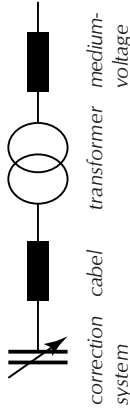

$$f_r = 50\text{Hz} \cdot \sqrt{\frac{S_k}{Q_c}}$$

- $S_k$**  = short-circuit power at the point where the correction system is connected
- $Q_c$**  = correction system capacitor power rating

The short-circuit power  **$S_k$**  at the point where the power factor correction system is connected is

- determined essentially by the transformer ( **$S_n / u_k$** ),
- reduced by some 10 % by the impedance of the medium-voltage system
- possibly greatly reduced by long lengths of cable between the transformer and the power factor correction system.

### Example:

- transformer 1000 kVA,  $u_k = 6\%$
- short-circuit power of the medium-voltage system 150 MVA,  **$S_k \approx 12.6$  MVA**
- power factor correction system 400 kVAr in 8 stages, unchoked

Capacitor power rating ( <b><math>Q_c</math></b> )	Resonant frequency ( <b><math>f_r</math></b> )
100 kVAr	562 Hz
250 kVAr	355 Hz
400 kVAr	281 Hz

When the capacitor stages of the correction system are switched in, the network resonance frequency  $f_r$  changes considerably and is repeatedly close to the frequency of the network harmonic.

If the natural resonance of this oscillatory circuit is near to a network harmonic that is present, it is to be expected that resonance will increase the harmonic voltages. Under certain conditions, these may be multiplied by an amount approaching the network Q-factor (in industrial systems about 5-10!):

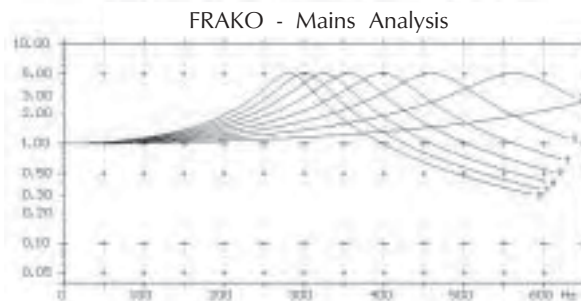

**Fig. 34:** Amplification factor for harmonic voltages in an unchoked p.f. correction system in the low-voltage network

## When can dangerous network resonances occur?

From Fig. 34 it can be seen that it is possible to assess whether resonance problems can occur with harmonics. Simple rules suffice for this:

1.) If the resonant frequency is

- 10 % below/above a network harmonic, the latter will be amplified in a network with a high Q-factor (e.g. in the evenings and at night) **by a factor of up to 4.**
- 20 % above a network harmonic, the latter will be amplified in a network with a high Q-factor **by up to 2.5.**
- 30 % above a network harmonic, the latter will be amplified only slightly, **by a factor of up to 1.7.**

2.) In a network with no harmonic generator of its own, but with pronounced harmonics present in the medium-voltage system, the following can occur:

- at a resonance frequency below 400 Hz - resonance peaks of the 7th harmonics,
- **at a resonance frequency below 300 Hz - dangerous resonance peaks of the 5th harmonic.**

## What effect does the network configuration have on the problem of harmonics?

The network short-circuit power determines the resonance frequency and, where harmonic generators are present in that network, the amplitude of the harmonics in the network voltage.

- If the network short-circuit power at the point where the power factor correction system is connected is too low, this causes problems.
- If the short-circuit power is changed radically due to altered switching conditions, this causes problems.

### **Example:**

In many large commercial facilities continuity of power supply is achieved by connecting the low-voltage distribution points via a ring circuit. This network has a high short-circuit power even with large power factor correction systems and heavy rectifier loads with hardly any harmonics problems arising since the resonance frequency is high and the harmonic currents are dissipated with low voltage drops into the medium-voltage system. If a break is made in the ring circuit, for example for maintenance work, the short-circuit power can decrease considerably under certain conditions, so that the resonance frequency can fall below 300 Hz!

## Voltage and current loads on unchoked power factor correction systems

When resonance occurs, the network r.m.s. voltage only increases slightly, but the r.m.s. value of the capacitor current increases considerably. In the case of resonance with the fifth harmonic, this can reach a level of, say, 15% in which case:

- the network r.m.s. voltage increases by 1%
- the crest working line voltage increases by 10-15 % (depending on phase angle)
- **the r.m.s. value of the capacitor current increases by 25%!**

In the case of resonance with the 11 harmonic, this can reach a level of, say, 10 % in which case:

- the network r.m.s. voltage increases by 0.5%
- the peak value of the mains voltage increases by 6-10 %
- the r.m.s. value of the capacitor current increases by 50%!

**For this reason a high current-carrying capacity is one of the most important quality characteristics for a capacitor!**

For 400 V distribution systems a capacitor nominal voltage of 440 V is completely adequate, provided that these capacitors have a continuous current-carrying capacity of double the nominal current at **50 Hz.**



## What must be done if resonance is possible but rather unlikely?

A considerable proportion of installations being designed today fall into this category, e.g.:

- No internal harmonic generators installed in the network, no harmonics in the medium-voltage system, but a resonance frequency below 400 Hz.
- If changes are made in the network configuration, for example, during maintenance work, the resonance frequency can fall below 400 Hz. Harmonics are present in the medium-voltage distribution system.
- It is planned to build installations with rectifiers at a later date.

To protect an unchoked installation from the occurrence of resonance, even if this may only happen occasionally, it is highly advantageous to use the **EMA 1101 mains monitoring instrument**. This device monitors all three phases of the power supply system, shuts the installation down if a dangerous level of harmonics is exceeded and switches it automatically in again when this level falls below the critical value. The peak values that have occurred are stored, however, and can be retrieved via the EMA 1101 bus interface.

For distribution systems that are symmetrically loaded, the **EMR 1100 power factor control relay** can also be installed. This instrument monitors the system to detect any resonance that may occur. The EMR 1100 power factor control relay determines the harmonic voltages in the measured phase and calculates the r.m.s. current to the capacitors. If a programmed maximum limit is exceeded, the installation is shut down and switched in when the level falls below its critical value.

In cases of this description, power factor correction systems that can be retrofitted with chokes are often installed.

## Project engineering of power factor correction systems for networks with harmonics

The best information on the operational characteristics of a planned power factor correction system is obtained by a combination of two planning activities:

- Measuring the harmonic voltages and currents over several days with no power factor correction system installed.
- Theoretical calculation of the network resonance characteristics.

In the measured network the following harmonic levels are to be expected with PFC:

*Maximum value of the measurement without power factor correction multiplied by the resonance factor from the network analysis.*

### **Example:**

An average-size low-voltage system with a 1000 kVA transformer. The installation, complete with the p.f. correction system, is connected via two 20 m long cables laid in parallel (equivalent to the impedance of a 10 m cable). Only purely ohmic loads may be taken into account as equipment such as induction motors have no damping effect on harmonics. With a 400 kVAr installation and all capacitor sections switched in, the 5th harmonic (250 Hz) is amplified by a factor of about 3. At 250 kVAr the 7th harmonic is amplified by a factor of about 4!

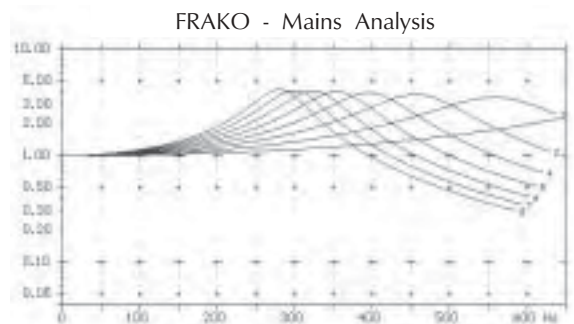

**Fig. 35:** Amplification of harmonic voltages in relation to the capacitor stages switched in

During the day, with increased network damping, these factors are lower, but in the evenings and at weekends the amplification factor for the 7th can be higher.

## Measures to counteract expected resonances

If harmonics with high voltage levels, such as:

4 %	of the	3rd harmonic	(150 Hz)
5 %	of the	5th harmonic	(250 Hz)
4 %	of the	7th harmonic	(350 Hz)
3 %	of the	11th harmonic	(550 Hz)
2.1 %	of the	13th harmonic	(650 Hz)

due to resonance induced amplification are anticipated when planning a power factor correction system, serious disruptions can occur in the low-voltage distribution system:

- problems with IT systems and CNC machines
- damage to rectifiers and/or converters
- uncontrolled tripping of a variable capacitor bank and circuit breakers
- shutdown of unchoked power factor correction systems
- voltage peaks in the distribution system
- increased eddy current losses transformers and induction motors

If the level of individual harmonics with no power factor correction system amounts to more than 1.5 % (7th and higher harmonics) or 2% (5th harmonic) and the resonance frequency of the network can be close to these harmonics, then it must be assumed that these permissible limits will be exceeded by resonance-induced amplification.

In situations of this type, only choked power factor correction systems should be used in order not to jeopardise the reliability of the low-voltage distribution system.

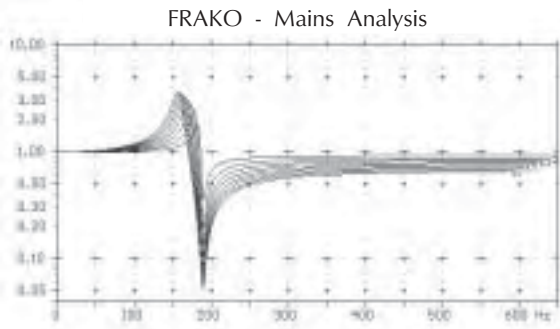

*Choking reduces the resonance frequency to a value below 250 Hz. All harmonics above the resonance frequency of the choked system are attenuated.*

**Fig. 36:** Damping of harmonic voltages as a function of the choked capacitor sections

A choked capacitor consists of a capacitor in series with a filter reactor. Its series resonance frequency is adjusted by appropriate design of the filter reactor so that it is below the frequency of the 5th harmonic (250 Hz). This combination therefore has an inductive characteristic for all frequencies above the series resonance frequency. Resonance between the capacitors and the reactive network impedances is no longer possible. A choked system suppresses some of the harmonic currents. To prevent overloads due to the 5th harmonic still present in the network, it is present-day practice to adjust the resonance frequency of the choked circuit to 189 Hz or less.

The choked circuit is characterised either by the capacitor-choke resonance frequency ( $f_r$ ) or by the relative voltage drop ( $p$ ) at the choke. These two parameters are related by the following formula:

$$f_r = 50\text{Hz} \cdot \sqrt{\frac{1}{p}}$$

For example:  $p = 0.07$  (7%)  
 $f_r = 189\text{ Hz}$

The impedance of the choked capacitor at 250 Hz is smaller than the impedance of the unchoked capacitor by a factor  $x$ .

The choked power factor correction system has the following characteristics for the 5th harmonic:

- Acceptor circuit behaviour when  $2x > 1$
- Rejector circuit when  $x < 1$

With strong acceptor circuit behaviour (series resonant circuit), the maximum allowable level of the 250 Hz harmonic must be limited so as not to overload the filter reactor.

• $p = 5.7\%$	$f_r = 210 \text{ Hz}$	$x = 2.4$	→ $u_{250 \text{ max}} = 4 \%$
• $p = 7\%$	$f_r = 189 \text{ Hz}$	$x = 1.33$	→ $u_{250 \text{ max}} = 5 \%$
• $p = 8\%$	$f_r = 177 \text{ Hz}$	$x = 1.0$	→ $u_{250 \text{ max}} = 5 \%$
• $p = 13.5\%$	$f_r = 136 \text{ Hz}$	$x = 0.42$	→ $u_{250 \text{ max}} = 5 \%$

### Example:

If 4 % of the 5th harmonic is superimposed on the network voltage, a choked power factor correction system attenuates the 5th harmonic as follows:

• at 7 % choke:	by $4\% \times 5$	$(=250 \text{ Hz}/50 \text{ Hz})$	$\times 1.33 = 0.27 \times I_n$
• at 5.7 % choke:	by $4\% \times 5$	$(=250 \text{ Hz}/50 \text{ Hz})$	$\times 2.4 = 0.48 \times I_n$
• at 13.5 % choke:	by $4\% \times 5$	$(=250 \text{ Hz}/50 \text{ Hz})$	$\times 0.42 = 0.08 \times I_n$

( $I_n$  = system nominal current at 50 Hz)

When designing a choked power factor correction system the following factors must always be taken into account:

- Choked and unchoked capacitors must never be operated in parallel on the same low-voltage system.
- Parallel operation of filter circuit systems with different choke factors ( $p$ ) is possible, but the loading of the filter circuits is different and should be accurately analysed at high levels of harmonics.
- If the low-voltage systems are electrically isolated (transformers not capable of being coupled at the low-voltage side), then, if required, one network can be choked while the other system has a power factor correction without a choke.
- The type of installation selected must comply with the requirements of the utility company concerned.

### Power factor correction in networks with audiofrequency remote control systems

Audio frequency remote control systems are installed in utility company supply networks in order to perform switching functions (such as tariff changeover) by means of special receivers in the customer's circuit. To do this, control voltages at a high frequency (audiofrequency pulses) are superimposed on the power distribution system. These frequencies are usually in the range of 166 to 1350 Hz.

In order not to interfere with the functioning of these remote control systems, the control voltage level must not be unduly disrupted by the customer's installation. To ensure this, members of the German Electricity Association (VDEW), Austrian Association of Electricity Utilities (VEÖ) and Association of Swiss Electricity Suppliers Association (VSE) have produced their "Recommendations For Preventing Impermissible Disturbances in Audio Frequency Remote Control".

An impedance factor  $\alpha^*$  is used for the assessment of networks with installed power factor correction systems.

*The impedance factor  $\alpha^*$  is the ratio of the audiofrequency impedance to the 50 Hz impedance in the customer's installation.*

**At an impedance factor of  $\alpha^* \geq 0.5$  no interference is to be expected with remote control systems.**

## Effect of unchoked power factor correction systems

An unchoked power factor correction system together with the reactive network impedances constitute an oscillatory circuit. The resonance frequency ( $f_r$ ) of this oscillatory circuit decreases with increasing p.f. correction power rating. Due to the resonance frequency the impedance of the oscillatory circuit is at a very low value and can considerably attenuate the voltage level of the audiofrequency control system.

FRAKO - Mains Analysis

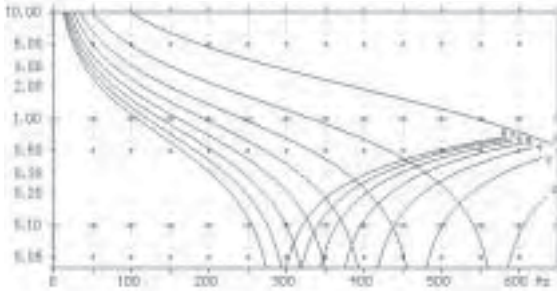

When the power correction system is fully switched in, an impedance factor of  $\alpha^* \geq 0.5$  will only suffice for a remote control frequency of 166 Hz.

**Fig. 37:** Impedance factor  $\alpha^*$  in relation to the switched-in capacitor stages

If the impedance factor cannot be maintained, an audiofrequency rejector circuit must be installed in series with the power factor correction system. An audiofrequency rejector circuit is an anti-resonant circuit consisting of a blocking choke and a resonance capacitor. It is designed for the nominal rating of the power factor correction system and its nominal voltage. An audiofrequency rejector circuit increases the impedance of the power factor correction system at that audiofrequency to an impedance factor  $\alpha^* \geq 0.5$ .

FRAKO - Mains Analysis

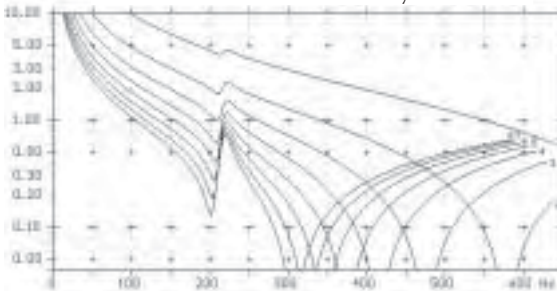

With the power factor correction system switched in, an impedance factor of  $\alpha^* \geq 0.5$  is achieved with certainty for a remote control frequency of 216.7 Hz.

**Fig. 38:** Impedance factor  $\alpha^*$  in relation to the switched-in capacitors when in series with an audiofrequency rejector circuit for 216.67 Hz

## Critical remote control frequencies in the range 270 to 425 Hz

Placing an audio frequency rejector circuit in series with the power factor correction system changes its resonant frequencies. In particular, an unchoked power factor correction system has a second series resonance frequency below the blocked remote control frequency. In the audiofrequency range 270 to 425 Hz, dangerous resonance-induced accentuation of harmonics can occur.

The following rules therefore apply in these cases:

FRAKO - Mains Analysis

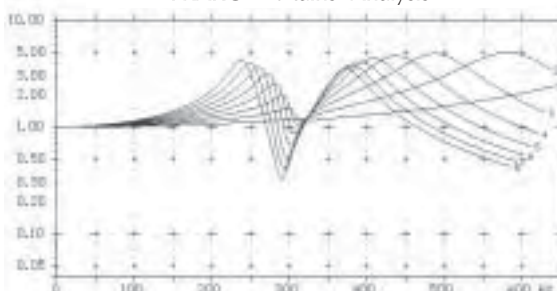

**Fig. 39:** Amplification of the harmonics when using an unchoked power factor correction system with an AF rejector circuit for 316.7 Hz

If audiofrequency rejector circuits in the range 270 Hz to 425 Hz are arranged in series with unchoked power factor correction systems, there is an increased likelihood of resonance immediately near to the 5th and 7th harmonics. In order to prevent both the audiofrequency rejector circuit and the power factor correction system being overloaded, the level of the 5th harmonic (250 Hz) and the 7th harmonic (350 Hz) must not exceed 1% each of the nominal supply voltage. If higher levels do occur, choked power factor correction systems must be installed.

## Effect of choked power factor correction systems

Choking power factor correction systems reduces the resonance frequency, as already described earlier in detail, to a value below 250 Hz. All harmonics above the resonance frequency of the choked circuit are no longer amplified but attenuated. This gives adequate impedance factors  $\alpha^*$  for remote control frequencies sufficiently far away from the resonance frequency of the choked circuit.

Depending on the exact design of the circuit, remote control frequencies can be reliably blocked when using choked power factor correction systems even without having an audiofrequency rejector circuit.

In view of the maximum reliability required of power factor correction systems and the interference-free transmission of remote control signals called for by utility companies, we recommend the following for a correction factor (ratios of transformer power to PFC capacitor power rating) of up to 50%:

Utility company remote control frequency (in Hz)	Rejector circuit (percentage choke)
166 to 183,3	p = 7 % (FK189) with AF rejector circuit
190 to 210	p = 8 % (FK177) with AF rejector circuit
$\geq 216.7$	p = 8 % (FK177) without AF rejector circuit
$\geq 228$	p = 7 % (FK189) without AF rejector circuit

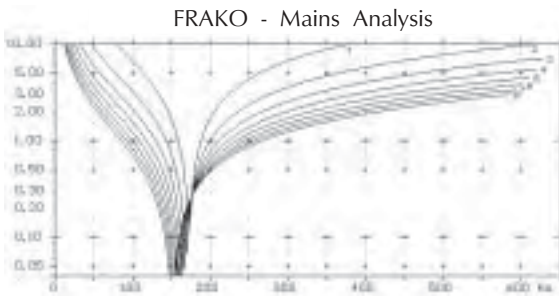

**Fig. 40:** Example 1: Impedance factor  $\alpha^*$  in relation to switched-in capacitors, with 8% choke

For frequencies  $\geq 216.7$  Hz an impedance factor  $\alpha^* \geq 0.5$  is achieved with certainty in this case even without an audiofrequency rejector circuit.

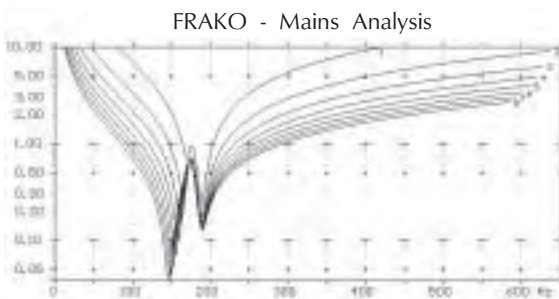

**Fig. 41:** Example 2: Impedance factor  $\alpha^*$  in relation to switched-in capacitors, with 7% choke plus audiofrequency rejector circuit for 175 Hz

The impedance factor  $\alpha^* \geq 0.5$  is reached with certainty in all stages.

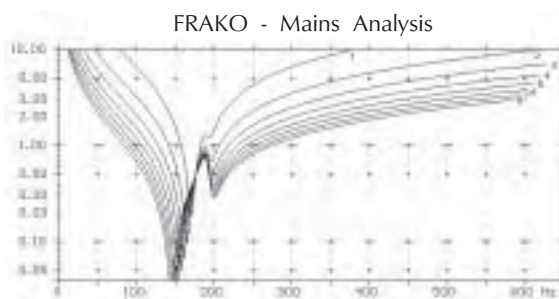

**Fig. 42:** Example 3: Impedance factor  $\alpha^*$  in relation to switched-in capacitors, with 8% choke plus audiofrequency rejector circuit for 190 Hz

In this case as well, the impedance factor  $\alpha^* \geq 0.5$  is reached with certainty in all stages.

These recommendations are based on years of practical experience by the members of the German Electricity Association (VDEW), Austrian Association of Electricity Utilities (VEÖ) and Association of Swiss Electricity Suppliers Association (VSE) who have issued their "Recommendations For Preventing Impermissible Disturbances in Audio Frequency Remote Control" in 1993.

### Other versions of choked power factor correction systems

#### 1.) 12.5 to 14% choke:

A version with 12.5 to 14% choke is an inexpensive variant with no audiofrequency rejector circuit for distribution systems with remote control frequencies of 166 to 210 Hz. The essential disadvantage of this version is in its low absorption capability for harmonics. In low-voltage networks with high levels of the 5th harmonic, the use of these versions should not be considered especially for systems > 200 kVAr. Instead, a version with  $p = 7\%$  or  $8\%$  and an audiofrequency rejector circuit should be selected. Low-voltage networks with extremely high levels of the 3rd harmonic (150 Hz) are, however, an exception. The 3rd harmonic is produced as a rule by a highly asymmetrically loaded low voltage network (e.g. operation of single-phase equipment such as welding sets, UPS systems or a large number of energy-saving lamps and computers).

#### 2.) 5 to 5.67% choke:

As a rule this version is used because of its increased absorption of harmonics. If, however, a high level of harmonics from the medium-voltage distribution system is fed to the network, the use of the 5 to 5.67% choked version should not be considered, in order to prevent overload conditions, and instead a version with  $p = 7\%$  should be selected. At extreme levels of harmonics, specially customised filter circuits can also be designed.

#### 3.) Combined choking:

This power factor correction system variant is constructed with filter circuit stages of different resonance frequencies (as a rule 12.5 / 13.5% and 5 / 5.67%). The number and ratings of the filter circuit stages are selected so that the power ratio approaches 1:1. Combined choked circuits can be used in networks with utility company remote control frequencies in the range 166 to 190 Hz as a more simple variant instead of using choked systems with audiofrequency rejector circuits.

### **Three important disadvantages must, however, be taken into account:**

- In order to maintain the blocking factor with certainty, the principle of uniform use for minimum wear and tear (=cyclic switching) of all units must be suppressed with variable banks of capacitors.
- The absorption effect on harmonics is lower than with choked systems with audiofrequency rejector circuits.
- One half of the system has a low absorption effect, while the other half acts as a filter circuit for 210/223 Hz like an acceptor circuit. With a high proportion of harmonics in the medium-voltage distribution system or in the facility's own network, one half of the filter circuit sections is always under full thermal load, while the other half is not. These loading conditions inevitably result in different life expectancies. For this reason a combined choking circuit is only advisable when it is necessary to use choking to prevent resonance occurring. An audiofrequency between 166 and 183 Hz is present, but only a low proportion of harmonic voltage (max. 3 %) is anticipated.

The technically more sophisticated solution is to use a choked version with an audiofrequency rejector circuit. The latter is adjusted precisely for the remote control frequency, and reliably blocks this. A rejector circuit is arranged in series with each power factor correction cabinet, and the harmonics are absorbed uniformly by all the stages. All the advantages of modern control technology applied to reactive power control relays can be fully exploited.

### Monitoring power factor correction systems in industrial facilities

The maintenance of power factor correction systems after their installation is just as important as the planning and design work beforehand. Once a power factor correction system has been commissioned, it is frequently forgotten about. The user is usually not reminded of the fact that the capacitor contactors are components subject to wear until the unpleasant effects of contactor failure have been experienced.

**Contactors are subject to high stress levels when switching capacitive loads.** Chattering switching contacts result in high charging and discharge currents in the capacitors and heavy wear and tear of the switching contacts themselves. Replacing the contactors in good time considerably prolongs the service life of the power factor correction system. **Switching cycle counters** have been integrated into state-of-the-art reactive power control relays such as the RM 9606, RM 9612 and EMR 1100 in order to give early information on the wear of the contactors. The reactive power control relay indicates the optimum point in time when the contactors should be replaced and thus helps to cut costs. For preventive maintenance purposes, the user can display the cumulative total of switching cycles for each individual stages.

Changed conditions in the network can also result in disturbances in the entire low-voltage power system. The purpose of network monitoring is to identify these disturbances at an early stage. An **EMA 1101 mains monitoring instrument** offers you the possibility of being alarmed in good time before the system or system components fail. All parameters relevant to safety and reliability in medium- and low-voltage systems, the temperatures of sensitive system components and the consumption of active and reactive energy are registered, analysed and monitored.

## What must be done if the harmonic factor is high but the reactive power demand is small?

Basically there are several solutions to limit harmonic currents caused by the use of loads that inevitably generate them.

Well-known measures to solve this problem include the use of

- several passive filters tuned to work together (tuned acceptor circuits) or
- assembling highly non-linear loads and sensitive consumers into separate groups, feeding each group by means of a separate transformer.

However, these solutions involve two main disadvantages:

- Improvement of the system disturbance characteristics applies only to the particular installation involved. Each subsequent extension can mean that the initial investment becomes worthless.
- It is often very difficult to implement these solutions in practice for an existing installation.

Excessively high harmonics levels often occur due to the use of unchoked capacitors in networks that are distorted by harmonics.

Today, the most cost-effective solution for these problems is still the use of heavy duty FRAKO filter circuit systems.

For problems with:

- excessively high levels of the 3rd, 9th and 15th harmonics and the high neutral conductor current they give rise to, or
- the demand for tuned acceptor circuits to maintain the harmonic current returned to the medium-voltage system under a specified limit or
- low demand for reactive power but high harmonic currents, for example, due to a large proportion of converter-controlled induction motors

The OSF active filter or a combination of a FRAKO filter circuit system with an active filter is the optimum solution.

The decisive advantage of an active harmonic filter lies in the fact that the correction of network disturbances still remains effective if subsequent extensions are made to the installation. The flexibility of the FRAKO active filter means that the required nominal size can be selected quite simply from the current demand. Any additional demand due to extensions of the installation can be met at any time by adding further components.

## Operating principle of the active filter

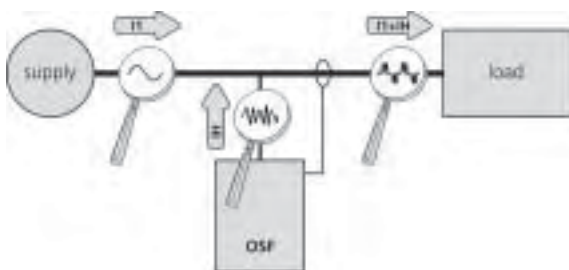

$I_1$  = fundamental current  
 $I_H$  = harmonic current

The active filter is installed in parallel to the harmonic generators. It analyses the harmonic current produced by the nonlinear loads and supplies a 180° out-of-phase compensating current, either over the entire spectrum from the 2nd to the 25th harmonic or a specially selected harmonic. This action neutralises the corresponding harmonic currents completely at the point of connection, provided that the system has been appropriately dimensioned.

**Fig. 43:**  
 Operating principle of the active filter type OSF



The combination of harmonic filter and harmonic load appears to the network as an overall linear load drawing a sinusoidal current. Installation is quite simple. A three-phase feeder with or without a neutral conductor needs to be available. The current transformer is then installed in the line to the non-linear load.

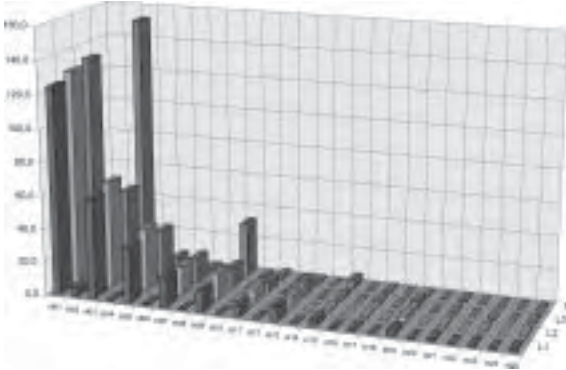

**Fig. 44:**  
*Harmonics measured, without filter*

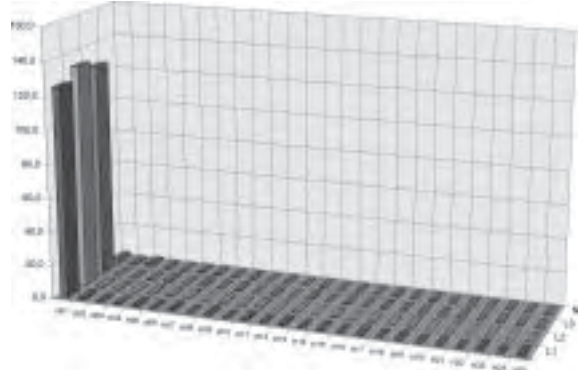

**Fig. 45:**  
*Harmonics measured in the same network, with filter*

### **Applications**

Typical applications are in:

- Low-voltage systems with many converters that are under an obligation to return only limited harmonic currents to the preceding network, where, for example, long spur lines to remote installations are involved.
- Modern converter drives that return high levels of harmonics to the distribution system, but with only a low demand for reactive power. In a low-voltage network with a 1000 kVA transformer and many small induction motors in use, it is quite possible that a power factor correction system rated at 400 kVAr is necessary. When modern converters are used, the demand still amounts to some 100 kVAr.
- Low-voltage systems with a large proportion of the third harmonic due to the use of single-phase loads. These low-voltage networks display an extraordinarily high current in the neutral conductor which should be approximately 0 A when the load is distributed almost symmetrically. Because of the electronic loads, however, the harmonic currents in the three phases are added together in the neutral conductor in addition to any imbalance in the ohmic loads. This is because the 3rd, 9th and 15th harmonics in the three phases have the same phase angle. The result is a current in the neutral conductor, which, under certain conditions, can be greater than the phase current and overloads the neutral conductor, which has not been dimensioned for loads of that magnitude.



# Manual of Power Factor Correction

## Sales Programme

Power capacitors for low and medium voltage

Power factor correction systems

Power factor correction systems with reactors

Modules for power factor correction systems

Active filters

Dynamic compensation of harmonics

Reactive power control relays

Maximum demand control systems

Mains monitoring instruments

Cost allocation

Energy management systems

**Reliable energy solutions.**

**FRAKO** Kondensatoren- und Anlagenbau GmbH  
Tscheulinstr. 21a · D-79331 Teningen · Germany  
Phone +49 76 41/453-0 · Fax +49 76 41/453-5 45  
<http://www.frako.de> · E-Mail: [info@frako.de](mailto:info@frako.de)